

Solving Inductive Reasoning Problems in Mathematics: Not-so-Trivial Pursuit

LISA A. HAVERTY

KENNETH R. KOEDINGER

DAVID KLAHR

MARTHA W. ALIBALI

Carnegie Mellon University

This study investigated the cognitive processes involved in inductive reasoning. Sixteen undergraduates solved quadratic function-finding problems and provided concurrent verbal protocols. Three fundamental areas of inductive activity were identified: Data Gathering, Pattern Finding, and Hypothesis Generation. These activities are evident in three different strategies that they used to successfully find functions. In all three strategies, Pattern Finding played a critical role not previously identified in the literature. In the most common strategy, called the Pursuit strategy, participants created new quantities from x and y , detected patterns in these quantities, and expressed these patterns in terms of x . These expressions were then built into full hypotheses. The processes involved in this strategy are instantiated in an ACT-based model that simulates both successful and unsuccessful performance. The protocols and the model suggest that numerical knowledge is essential to the detection of patterns and, therefore, to higher-order problem solving.

One of his teachers, apparently eager for a respite from the day's lessons, asked the class to work quietly at their desks and add up the first hundred whole numbers. Surely this would occupy the little tykes for a good long time. Yet the teacher had barely spoken, and the other children had hardly proceeded past " $1 + 2 + 3 + 4 + 5 = 15$ " when Carl walked up and placed the answer on the teacher's desk. One imagines that the teacher registered a combination of incredulity and frustration at this unexpected turn of events, but a quick look at Gauss's answer showed it to be perfectly correct. How did he do it?

William Dunham, *Journey Through Genius*, 1990, 236–237.

I. INTRODUCTION

He did it by inductive reasoning. Inductive reasoning is defined as the process of inferring a general rule by observation and analysis of specific instances (Polya, 1945)¹. Gauss recognized a pattern: that the numbers from 1 to 100, when added together from end to end (i.e., $1 + 100$; $2 + 99$; $3 + 98$; etc.) always equal 101. He inferred that there would be 50 such pairs, and thus, he multiplied 101 by 50 to reach the answer that $1 + 2 + 3 + \dots + 100 = 5050$. But our dear Gauss did not stop there. He realized that the sum of the numbers from 1 to n would always be expressible in this way: $n + 1$ times $n/2$. Thus, he induced the formula that $n * (n + 1)/2$ equals the sum of the numbers from 1 to n .

The Role of Inductive Reasoning in Problem Solving and Mathematics

Gauss turned a potentially onerous computational task into an interesting and relatively speedy process of discovery by using inductive reasoning. Inductive reasoning can be useful in many problem-solving situations and is used commonly by practitioners of mathematics (Polya, 1954). Research has established the importance of inductive reasoning for problem solving, for learning, and for gaining expertise (Bisanz, Bisanz, & Korpan, 1994; Holland, Holyoak, Nisbett, & Thagard, 1986; Pellegrino & Glaser, 1982). Indeed, Pellegrino and Glaser (1982) noted that “the inductive reasoning factor. . . , which can be extracted from most aptitude and intelligence tests, is the single best predictor of academic performance and achievement test scores.” (p. 277). Klauer (1996) notes that “problem-solving requires one to induce rules, i.e., to make use of inductive reasoning” and cites as evidence the rule induction work conducted by Simon and Lea (1974), the review of concept learning, serial patterns, and problem solving by Egan and Greeno (1974), and the investigation of expertise and problem solving in physics by Chi, Glaser, and Rees (1982). Even in problem domains that appear deductive on the surface, it seems that problem-solving knowledge is acquired primarily through inductive learning methods rather than through abstract rule following. Research on the Wason selection task, which nominally requires deductive knowledge of modus ponens and modus tollens, has shown that people solve such problems using either inductive methods based on concrete mental models (Johnson-Laird, 1983) or by applying semigeneral reasoning schemas induced from experience (Cheng & Holyoak, 1985).

The importance of inductive reasoning to learning is illustrated in work by Zhu and Simon (1987) about learning from worked-out examples. Students learned and were able to transfer what they learned when presented with worked-out examples from which they had to induce how and when to apply each problem-solving method. Klauer (1996) provides more direct evidence of the effect of inductive reasoning on learning. In his work, acquisition of declarative knowledge was improved after training in inductive reasoning. The role of inductive reasoning in mathematics learning was demonstrated by Koedinger and Anderson (1998). They showed that an instructional approach based on helping students induce algebraic expressions from arithmetic procedures led to greater learning than a textbook-based instructional approach.

TABLE 1
Klauer's (1996) System for Classifying Inductive Reasoning Tasks

Type of inductive reasoning task	Cognitive operations
Generalize	Detect similarity of attributes
Discriminate	Discriminate attributes
Cross classify	Detect similarity and differences in attributes
Recognize relationships	Detect similarity of relationships
Differentiate relationships	Detect differences in relationships
System construction	Detect similarity and differences in relationships

Finally, research has demonstrated the importance of inductive reasoning to the development of expertise. In addition to the work by Chi et al. (1982) in this area, work by Cummins (1992) demonstrates that induction of structural similarities between problems leads to expert-level conceptual performance when working with equations. Even in the domain of geometry theorem proving, expert representations seem to reflect inductive experience with diagrams rather than command of textbook definitions and theorems (Koedinger & Anderson, 1989, 1990). Thus, inductive reasoning facilitates problem solving, learning, and the development of expertise. It is fundamental to the learning and performance of mathematics, and is, therefore, an important process to investigate to gain a deeper understanding of mathematical cognition.

Function-Finding Task Is Representative of Inductive Reasoning

Recall our definition of inductive reasoning as the process of inferring a general rule by observation and analysis of specific instances. The literature covers a wide variety of inductive reasoning tasks: series-completion problems (Thurstone, 1938; Simon & Kotovsky, 1963; Bjork, 1968; Gregg, 1967; Klahr & Wallace, 1970; Kotovsky & Simon, 1973; Sternberg & Gardner, 1983), Raven matrices (Raven, 1938; Hunt, 1974; Sternberg & Gardner, 1983), classification problems (Goldman & Pellegrino, 1984; Sternberg & Gardner, 1983), analogy problems (Evans, 1968; Sternberg, 1977; Pellegrino & Glaser, 1982; Sternberg & Gardner, 1983; Goldman & Pellegrino, 1984). These varied tasks have been organized by Klauer (1996) according to the inductive processes that they require (see Table 1). In Klauer's classification system, several inductive processes are identified and each is paired with a specific cognitive operation, such as detecting similarities and differences in attributes and in relationships.

Klauer (1996) defines "comparing relations" to require "scrutinizing at least two pairs of objects," such that "understanding the series A-B-C requires mapping the relation between A-B and the relation between B-C" (Klauer, p. 47). He thus asserts that the classification problems in the literature are "generalization" problems according to this system. Similarly, because series-completion problems require noting similar relationships across instances, they are classified as problems of "recognizing relationships," and because matrix problems require the detection of both similar and different relationships from cell to cell, they are classified as "system construction" problems. We would also

x	1	2	3	4	5	6
y	1	4	9	16	25	36

Figure 1. Sample set of data for a function-finding problem.

classify number analogy problems (e.g., Pellegrino & Glaser, 1982) as “system construction” problems. The problem presented to young Gauss would not fall into any of the categories of problems studied in the literature, but in Klauer’s system it might be classified as a problem of “recognizing relationships.”

In this study, our goal was to examine the particular role of inductive reasoning in mathematics. Thus, we sought a numerical task that is not merely a puzzle, but which is applicable and basic to doing real mathematics. The task we chose was function finding, which requires detecting and characterizing both similarities and differences in the relationships between successive pairs of numbers. It is thus classified as a “system construction” problem in Klauer’s system. A basic example of a function-finding problem is to find a function that fits the data in Figure 1 (i.e., $y = x^2$).

The problem of finding functions from data is fundamental to mathematics, as we demonstrate in the next section, and to science as well. Furthermore, as an inductive reasoning task, it encompasses several of the inductive processes identified in Klauer’s system. Thus, the function-finding task is ideal both from the standpoint of representing inductive reasoning problems, and from the standpoint of being representative of mathematics in general.

Function Finding is Pervasive in Mathematics

Many problems of inductive reasoning in mathematics, as well as in the sciences, distill to a basic problem of inducing a function from a set of numbers. Function finding can be found in algebra, in geometry, in calculus, in number theory, in combinatorics, and so forth. Consider this example from geometry: Suppose you know that the measure of angle 1 in Figure 2 is equal to x degrees, and you are trying to find the measure of angle 2 in terms of x . However, you do not yet know the fact (or you have forgotten) that the measures of two angles that lie together on a straight line add up to 180° . You might measure several sets of such angles with a protractor, and record the measures from these examples in a table. Suppose you have collected the data instances displayed in Table 2.

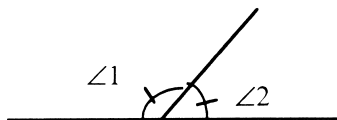

Figure 2. Given the measure of angle 1, find the measure of angle 2.

TABLE 2
Measures of Angle 1 and Angle 2

Angle 1	Angle 2
120	60
110	70
80	100
90	90

From these data instances you might induce that you can find the measure of angle 2 by subtracting angle 1 from 180° . At that point, you have successfully found the function that fits this data. Learning or recalling geometric conjectures by setting up and solving function-finding problems is an approach advocated by the National Council of Teachers of Mathematics (NCTM) and by some geometry textbooks (NCTM, 1989; Serra, 1989).

An example of how function finding appears in a very different field of math, combinatorics, is the following problem: Determine how many possible subsets there could be from a set of 10 elements. Some people will know how to calculate this answer without having to work out the actual individual sets at all. Others, however, will likely resort to the useful strategy of examining a smaller case as an example (Polya, 1945). Thus, one might first aim to discover how many subsets are possible from a set of only three elements, this being a case that is easily calculated by actually producing each of those subsets and then counting the total. Producing a few examples in this manner, we would begin to have some data. Thus, for the case where there are only two elements, there are 4 possible subsets (the sets: [a b], [a], [b], [null]). For a set of three elements, there are 8 possible subsets. For a set of 4 elements, there are 16 possible subsets (see Table 3).

We might now induce that there will be 32 possible subsets for a set of 5 elements, as the number of subsets for each set of “n” elements seems to be equal to 2, multiplied by itself “n” times. If this is the case, then we can multiply 2 by itself 10 times to determine the number of subsets for a set of 10 elements. Indeed, the answer to the problem is 2^{10} , or 1024.² The process just described is a process of function finding: investigating smaller examples to produce some data from which to infer a general rule that may then be applied to the instance of interest.

These examples illustrate how a problem that is not a function-finding task on the surface (e.g., how many subsets can be made of a set of 10 elements) may be converted

TABLE 3
Number of Possible Subsets from a Set of “n” Elements

No. of elements	No. of subsets
1	2
2	4
3	8
4	16

to a function-finding task in order to aid its solution. These examples demonstrate that function finding is valuable not only for making discoveries, but also as a heuristic for problem solving and recall. Function-finding skills may also facilitate learning in mathematics: Koedinger and Anderson (1998) showed that learning to translate story problems to algebraic expressions could be facilitated by using function finding as a scaffold during instruction. Thus, function finding plays multiple roles in mathematics: in discovery, problem solving, recall, and learning. In addition to its direct relevance to mathematics, function finding is also representative of inductive reasoning in general. Therefore, function finding is an important topic for investigation to improve our understanding of mathematical cognition.

Research on Function Finding

As function finding is so ubiquitous in mathematics, we sought to understand the cognitive processes involved in solving function-finding problems. The literature contains a number of studies that have examined function-finding behavior in the context of scientific reasoning (Huesmann & Cheng, 1973; Gerwin & Newsted, 1977; Qin & Simon, 1990). Participants in these studies were asked to discover a function that corresponded to a given set of data. Huesmann and Cheng put forth a theory of inductive function finding based on the hypotheses proposed by participants in their study. They found that functions involving fewer operations or less-difficult operations are proposed as hypotheses before more-difficult functions, and they identified addition, subtraction, and multiplication as less-difficult operators and division and exponentiation as more-difficult operators. Their theory characterizes induction as a process of search through a hierarchy of potential functions. Gerwin and Newsted (1977) elaborated on this theory and proposed a theory of "heuristic search," in which a participant infers a general class of likely hypotheses based on significant features of the data. Here we see the first acknowledgment of the process of data analysis as having a significant role in the hypothesis generation process.

These theories identify several processes involved in induction: search, hypothesis generation, and data analysis. However, because they were based mainly on solution-time data, these studies could not illuminate the actual cognitive processes being employed by participants. A deeper understanding of induction requires a much finer-grained examination of participants' behavior as they solve induction problems. Qin and Simon (1990) attempted to specify the cognitive processes of induction more directly. Participants in their study provided concurrent think-aloud protocols while they attempted to discover Kepler's Third Law ($x^2 = cy^3$) from a set of (x,y) data instances. Qin and Simon analyzed in detail the verbalizations of both successful and unsuccessful participants and were able to characterize many of their inductive problem-solving processes. Their results indicate that participants do indeed examine the data to inform their search for a hypothesis. They also found that linear functions were proposed most frequently, thus substantiating and further explicating the claim by Huesmann and Cheng that functions with fewer and less difficult operations are proposed before more difficult ones.

As a concrete instantiation of the function-finding process that they observed, Qin and Simon proposed that the BACON model, originally developed by Langley, Simon, Brad-

shaw, and Zytrow (1987), embodies search processes similar to those used by the participants in their study. The BACON model was developed to demonstrate that significant scientific discoveries can be accomplished by a small set of basic heuristics, and by a computer. The five heuristics of BACON can be summarized as follows: (1) Find a rule to describe the data; (2) Note any constant in the data; (3) Note any linear relation in the data; (4) If two sets of data increase together, then produce their quotient as a new quantity; (5) If two sets of data increase and decrease inversely to one another, then produce their product as a new quantity. Implicit in this set of heuristics is an iterative method of creating new quantities and subjecting these quantities to the same analyses to which the original x and y are subjected. Through this process, BACON eventually compares x to a quantity for which a clear functional relationship with x can be expressed. At this point, BACON will have solved the problem.

BACON's five discovery processes are direct and efficient. Indeed, they may be too efficient and advanced to suffice as a basis for understanding *student* inductive reasoning. Consider BACON's heuristic to determine whether the data represents a linear function. For many students the task of determining whether a set of data represents a linear function is a very involved and difficult process, one that would not be accomplished purely by inspection. It is likely that in a model of student function-finding performance, this linear heuristic would not be instantiated as a single process, as is the case for BACON, but as many subprocesses. Thus, we emphasize that BACON is an effective model of how rules can be induced from data, but an inappropriate model for adaptation to educational purposes. To understand and improve student performance, an elaboration of this concise model is needed.

One further issue with respect to the BACON model is its somewhat singular focus on hypothesis generation. We propose that induction involves not only hypothesis generation processes but also processes of finding patterns and gathering data. BACON addresses the process of finding patterns, whether constant, increasing, or decreasing. However, students' processes of finding patterns are more complex than these processes captured by BACON, and they merit further explication, both in terms of the activities involved and in terms of their relation to hypothesis generation activities. BACON also does not address the processes of collecting data and organizing it in preparation for analysis. In attempting to understand student inductive reasoning, we cannot assume the existence of adequate data collection and organization skills. A complete understanding of student inductive reasoning should specify the processes of finding patterns and gathering data in addition to generating hypotheses, for each of these areas is important to inductive reasoning.

In this study, we provide an in-depth analysis and characterization of data gathering and pattern finding processes and attempt to determine the relationship between these processes and the hypothesis generation process. To this end, the participants in this study collected and organized their own data so that we could observe and analyze these processes. The participants also provided verbal protocols (Newell & Simon, 1972) so that we would obtain the richest possible view of students' inductive reasoning capabilities and behaviors. We chose undergraduate students as our participant population because we aim to understand the processes of intelligent novices, rather than experts. Finally, we chose

to provide clean and accurate data for this initial investigation, rather than data containing noise or anomalies.

Understanding how inductive reasoning is done at this most basic level will be fundamental to understanding how it is conducted not only in similar situations, but also under more difficult conditions, such as might arise in scientific settings. Our analysis of the cognitive processes of function-finding will concern the strategies participants used when they succeeded at solving induction problems, and the differences between these solution paths and the paths of those who failed to solve the problems. The most common solution strategy observed will be instantiated in a cognitive model to make our theory of inductive reasoning explicit.

II. METHODS

Participants

Participants were 18 Carnegie Mellon University undergraduates with varying degrees of mathematical experience, ranging from no more than a high school algebra class to advanced college math courses. Two participants were dropped from the analyses for not following directions.

Materials

Materials included a pen and an ample supply of paper for solving each problem; a tape recorder and lapel microphone for recording verbal protocols; and a Hypercard, computer-interface program for generating data instances.

Task

Two function-finding problems ("F1" and "F2") were presented to each participant. Each participant was given the opportunity to generate up to 10 data instances for the problem at hand, using a Hypercard computer interface. For example, a participant might decide to begin by finding the value of y when x equals 7, and so would enter "7" into the interface by clicking the mouse 7 times and then clicking the "Done" button to see the corresponding y -value.³ Figure 3 shows the computer interface after a participant pressed the "Click" button 7 times for the x -value and the computer displayed the y -value of 14 in the answer box. In this manner, participants not only chose the order in which data instances were collected, but chose also *which* instances were collected, and *when* they were collected with respect to the remainder of the problem-solving process.

Participants were provided with paper and pen for solving the problems (the computer was used only for providing data), and were allowed up to 25 minutes per problem to discover a mathematical function of the form $f(x) = y$ that accurately described the relationship between the two variables, x and y . Participants were asked to find a closed-form function that related x and y , or, in other words, that could be used to directly

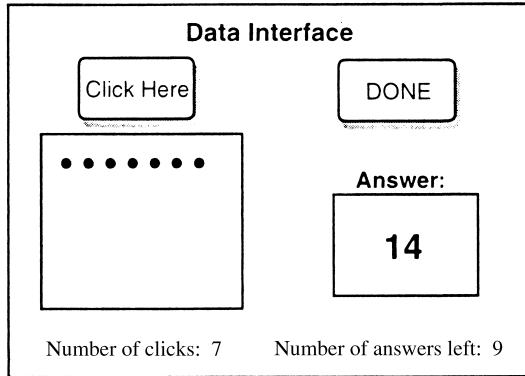

Figure 3. Example screen from data collection interface: collecting $f(7) = 14$.

compute y from x without repeated iterations. Recursive solutions were not accepted. Thus, $f(x) = 3x + 7$ was allowed, but $y_{n+1} = y_n + 3$ was not. Participants were also asked to find $f(1000)$. This request was employed as a concrete clarification of what is meant by “closed-form,” as pilot testing indicated (1) that many students would not comprehend the instructions without this concrete guide, and (2) that even the most determined participants would not attempt to generate $f(1000)$ with a recursive rule.

Both functions to be discovered were quadratics involving three operations, but participants did not know this. Figure 4 shows the functions used and a representative sample of corresponding data. All participants provided concurrent verbal protocols (Ericsson & Simon, 1993).

Procedure

All participants practiced talking aloud while solving some basic arithmetic tasks (Ericsson & Simon, 1993). They were then given written instructions about how to proceed in

	<u>X</u>	<u>Y</u>
Function 1 (F1)	3	0
$y = x(x-3)/2$	4	2
	5	5
$f(1000) = 498.500$	6	9
3 operations: -, *, ÷	7	14
	<u>X</u>	<u>Y</u>
Function 2 (F2)	1	3
$y = x(2x + 1)$	2	10
$f(1000) = 2.001.000$	3	21
3 operations: +, *, *	4	36
	5	55

Figure 4. Functions participants were asked to discover, with corresponding data.

generating data from the interface and about what they were to find. Participants were told “You will be asked to look for a relationship between two sets of numbers. . . . When you find this relationship, you will be able to find out what y is whenever you know what x is. Your task is to find what y is when x equals 1000. The way to do this is to find a general rule, so that if I give you x , you can tell me what y is.” The interface was then presented, ready with the data for the first problem. The experimenter was available at all times for questions or clarification. After 25 minutes, participants were asked to stop working on the current problem, any papers used were collected, and the participant was asked to begin the second problem in the same format. The order of the problems was counterbalanced across participants. Participants were corrected if they made any arithmetic errors in the course of solving a problem, as arithmetic ability was not the focus of this investigation. At the end of the hour-long session, participants were asked a number of questions about their mathematical education. No feedback was provided about the correct answer or about whether the answers given were correct.

Coding of Protocols

The verbal protocols were transcribed from the audio tapes and segmented according to a combination of breath pauses and syntactic criteria. The 15 protocols for F1 yielded 6331 lines, or segments. These segments were combined into meaningful episodes that were defined to represent completed thoughts or actions, or attempted complete thoughts or actions.

These protocols and their accompanying written work were originally coded at an extremely fine level of detail according to the activity or process occurring during the episode. This fine-level coding scheme consisted of 176 different codes that captured the exact nature of the mathematical processes occurring at each step of the problem solving. Once the protocols were understood at this fine level of detail, a broader coding scheme was applied, which grouped the fine-level codes into 16 broad categories. These 16 broad codes fall under three major categories of activity: Data Gathering, Pattern Finding, and Hypothesis Generation. These three activity groups and the 16 broad codes are listed in Appendix A, along with some examples of the fine-level codes that were categorized into them. The results discussed herein are based on this broader coding scheme, which provides a more manageable level of description for the data set.

III. RESULTS

Only closed-form functions, as described in the Method section, were coded as correct solutions to the problem. We expected F1 to be more difficult to discover than F2 because it included division (see Figure 4), which was identified by Huesmann and Cheng (1973) as an operation that makes discovery of a rule more difficult. F1 was indeed more difficult to discover than F2. Fifteen out of 16 participants discovered F2, whereas only 9 of the 16 participants discovered F1 (Fisher’s Exact, $p = .02$). Problem order did not significantly affect performance. Our analyses focus on the protocols for F1, which better

differentiated between participants and which therefore allow for examination of differences between successful and unsuccessful participants.⁴

Before discussing the activities observed in the protocols, we address the possibility of a correlation between success and mathematics achievement. We used self-reported Math SAT scores as an indicator of mathematics background. The four participants with the lowest Math SAT scores (450–610) were unsuccessful. Furthermore, the mean SAT score of the successful participants was higher than that of the unsuccessful participants, $F(1,14) = 4.03$, $p = .07$.

It is possible that unsuccessful participants failed only because they did not suspect that something as “complicated” as a quadratic function would be necessary to solve these problems. To address this possibility, we examined whether participants showed evidence of having considered quadratic formulas. The successful participants, by definition of having succeeded, necessarily “considered” quadratic functions. Among the six participants who failed to solve F1, only three ever created quadratic quantities in the course of searching for a solution to F1. (This difference between successful (9/9) and unsuccessful (3/6) participants is statistically significant, $p = .04$, Fisher’s Exact.) However, 15 of the total 16 participants succeeded at solving F2, which is also quadratic. These figures indicate that the participants did consider quadratic functions to be “fair game” when looking for solutions to these problems.

The remaining empirical results are presented in two sections. We first consider the types of activities the participants used and how they are coordinated. We then consider the different strategies the participants used to solve the problem successfully. Finally, we present a cognitive model that instantiates the processes observed in the protocols.

Types of Activity Observed

Based on a protocol analysis of participants solving problem F1, we identified three fundamental types of inductive reasoning activity: Data Gathering (DG), Pattern Finding (PF), and Hypothesis Generation (HG). Data Gathering is defined to include both data collection activities and the organization and representation of that data (such as making a graph or a table). Pattern Finding, by contrast, includes activities associated with investigation and analysis of that data, such as examination, modification, or manipulation of numerical instances for the purpose of understanding the quantity in question or for the purpose of creating a new quantity for examination. Examples of PF activity include the following: (1) Compute the differences between successive y values, for example, for instances (3,0), (4,2), and (5,5), the successive y differences are $2 - 0 = 2$ and $5 - 2 = 3$; (2) Compute the differences between x and y values, for example, for the instances (3,0) and (4,2), the $x - y$ differences are $3 - 0 = 3$ and $4 - 2 = 2$; (3) Compute a quantity from previously existing quantities, for example, for instances (3,0) and (4,2), $y/x = 0$ and $1/2$, respectively. Finally, Hypothesis Generation encompasses the activities of constructing, proposing, and testing hypotheses that might fit the data. HG activities utilize information culled from DG and PF activities, but this flow of information is not unidirectional. PF and DG may utilize information from HG and from each other: the

discovery of a pattern in the data (PF) might lead to the collection of a specific data instance (DG) to test whether the pattern holds more generally; a hypothesis that when tested does not fully account for the data (HG) might spark a round of PF activity to determine whether some pattern is apparent in the discrepancy between the actual data and the data produced by the hypothesis.

Data Gathering

Collection. Our design permitted a unique opportunity for investigation of DG activities. We describe notable features of the DG observed in the protocols and then briefly discuss the differences observed between the DG of successful versus unsuccessful participants. Participants collected between 5 and 10 data instances, with an average of 8.6.⁵ Participants tended to collect instances for small values of x (i.e., numbers from 1 to 10), and most participants (13 out of 16) collected $x = 3$, $x = 4$, $x = 5$, $x = 7$, and $x = 10$.⁶ The collection of data instances above $x = 10$ was idiosyncratic; however, participants exhibited a preference for collecting multiples of 5 and 10 (10 itself being widely popular, and 15, 20, 25, and 30 being the only instances larger than 12 that were collected by more than 1 participant.) Participants *did not* collect instances in strict order, such as $x = 3$, $x = 4$, $x = 5$, $x = 6$, as one might expect. However, participants did create unbroken sequences of instances by choosing x -values that filled gaps in a data set. For example, if the instances $x = 3$, $x = 6$, and $x = 5$ had been collected, a participant would likely collect $x = 4$ to complete the sequence. Most participants (15 out of 16) did eventually possess an uninterrupted sequence of instances with x -values in the range of 3 to 10. (One participant chose instead to have a sequence with intervals of 10 and collected the instances $x = 10$, $x = 20$, $x = 30$ for a sequence.) These uninterrupted sequences ranged from 3 to 9 instances in length, with an average longest sequence of length 6.

Organization. Contrary to what might be expected, participants did not organize all their data into ordered lists or tables, with x -values listed in ascending or descending order. The length of the longest such representation for each participant ranged from 2 to 8 instances in length, with a mean of 5. Few participants attempted to graph or otherwise pictorially represent the data for F1 or F2, in contrast to the participants from the Qin and Simon study. There was one attempt to graph the data for F1, which was not completed, and one other participant favored number lines as a way of examining the data, but these were the only two occurrences of pictorial representations. Thus, such strategies will not be discussed further in this paper.

In terms of distinguishing successful from unsuccessful participants, DG activities reveal no notable distinctions. Unsuccessful participants collected slightly more data instances than successful participants (mean: 9.4 for unsuccessful, 8 for successful, $F(1,14) = 4.74$, $p = .05$), and also made slightly longer ordered tables than successful participants (mean: 5.7 for unsuccessful, 4.6 for successful, $F(1,14) = 1.09$, $p = .31$), which may reflect compensation by unsuccessful participants for a lack of progress in hypothesis formation (in other words, they may have collected or organized data instances

TABLE 4
Quantities Created by Participants on F1, In Order of Popularity

Quantity	x	y	y/x	y - x	x - 3	y diffs	y factors	y - x diffs	x diffs	y/x diffs
Data Values	3	0	0	-3	0	—	—	—	—	—
	4	2	1/2	-2	1	2	2: 2*1	1	1	1/2
	5	5	1	0	2	3	5: 5*1	2	1	1/2
	6	9	3/2	3	3	4	9: 3*3	3	1	1/2
	7	14	2	7	4	5	14: 7*2	4	1	1/2
Of 15 participants			8	7	5	5	4	3	3	2

Note. The abbreviation “diffs” refers to “differences”.

when they could think of nothing else to do). However, unsuccessful participants collected essentially the same information as the successful participants (there are no differences of statistical significance in the exact instances that were collected by successful vs. unsuccessful participants.) Note, however, that these results *do not* suggest that all participants were at “ceiling” with respect to data organization skills. To the contrary, the nonsignificant results indicate that successful and unsuccessful participants performed similarly at organizing data and at collecting data, and the protocols and written materials indicate that the data organization skills displayed were less than exemplary (see Appendix C for the written work of one successful participant). Apparently, nicely-ordered tables of data are not necessary for discovering rules from that data, as might be expected.

Pattern Finding

Pattern Finding for the x and y quantities generally resulted in the creation of new quantities from these two original quantities. Participants created between 1 and 8 new quantities overall, with an average of 3.4. A common example of a newly created quantity is “y - x.” A participant examining the functional relationship between x and y might create this quantity to determine the difference between the corresponding values of x and y. Another method of assessing the discrepancy between x and y is to take their ratio. In fact, forms of y/x and y - x were the most popular quantities computed by participants (8 out of 15 participants created either y/x or x/y, and 7 out of 15 created either x - y or y - x. In this paper, we use “y/x” and “y - x” as shorthand for the quotient and difference of x and y in either order). Other popular quantities are listed in Table 4 in order of frequency among participants.

To clarify the nature of these quantities, we provide two examples. Given a column of y data containing the values (0 2 5 9 14) as in F1, a participant would compute “y differences” by determining the difference between each pair of consecutive values in the column. Thus, 2 - 0 = 2; 5 - 2 = 3; 9 - 5 = 4; and 14 - 9 = 5. Therefore, the column for the quantity “y differences” contains these values: (2 3 4 5). Given that same original column of y values, a participant would compute “y factors” by listing any factor pairs that would produce the given y value. Thus, for y = 9, 3 * 3 is a factor pair. For y = 14, 2

* 7 is a factor pair. If there were a $y=20$, it would have multiple factor pairs: $2 * 10$, $4 * 5$.

The quantities in Table 4 are all reasonably useful and informative to the participants. We have provided some motivation for why “ y/x ” and “ $y - x$ ” would be common quantities. The other quantities in Table 4 are informative as well. Computing the “differences” within any quantity is useful because it reveals how quickly the quantity is increasing or decreasing. The quantity $x - 3$ is informative in this particular problem because $x - 3$ yields y for the first instance in the problem: instance (3,0). Of course it is also the case that by computing $x - 3$, one translates the x values so that they begin at 0, which was aesthetically pleasing to some participants. As for “ y factors,” it seems that this computation becomes salient whenever there is a y value present that “lends itself” to factoring; in other words, when there is a y value present for which the participant readily perceives a factorization, such as for $y = 14$ or $y = 9$. This information can be very valuable if a pattern emerges from the factors of a sequence of y values. Thus, participants found many ways to manipulate the original data to make sense of it.

As important as PF is, successful and unsuccessful participants are not distinguished by their use of PF. In fact, the basic PF processes used by both groups were virtually identical. What does distinguish the two groups is the activity that *follows* the creation of a quantity. Successful participants do not merely compute quantities; they *analyze* them. Having computed some quantity q , the successful participant seeks to learn something *about* q . Is there anything of interest or of value about this new quantity? Can it shed any light on the investigation underway if it is probed a little? Successful participants use pattern recognition knowledge to make good decisions about which intermediate quantities are worthwhile objects of pursuit. We define the construct of “pursuit” to characterize this crucial process. The essence of pursuit is to treat a newly created quantity as one would y , the original quantity. In other words, subject the new quantity to analyses; take the differences between its values; form new quantities from it, and so forth. Each of the successful participants actively pursued intermediate quantities. We return to this construct when we consider the strategies participants used to succeed at this task. Now we turn to the third and final type of inductive activity observed in the protocols.

Hypothesis Generation

Participants made use of two methods for generating hypothesis ideas. The first method involves creating a hypothesis that works for a local (x,y) instance; the second, expressing an observed pattern in terms of x . Every participant created “local hypotheses,” in which a single instance is used as the basis for creating a hypothesis (usually a simple, single-operator hypothesis) that fits that instance. For example, for the instance (4,2), participants generally produced the local hypotheses $\{x \div 2 = y\}$ and $\{x - 2 = y\}$. Table 5 lists some common local hypotheses. Although such local hypotheses rarely led directly to the answer for F1, they often formed the basis of later, more advanced hypotheses. For example, the local hypotheses $\{x - 3\}$ and $\{x/2\}$ can both be considered as elements of the final solution: $\{(x/2) * (x - 3)\}$. In a later section we will characterize these particular

TABLE 5
Sample of Common Local Hypotheses for
Single Instances

Instance	Local hypotheses
(3, 0)	$x - 3$
(4, 2)	$x/2, x - 2$
(7, 14)	$x + 7, 2x$
(8, 20)	$x + 12$
(9, 27)	$3x, x + 18$
(10, 35)	$3.5x, 3x + 5, x + 25$
(15, 90)	$x + 75, 6x$

local hypotheses in terms of pieces of a puzzle, because they are the elements that must be put together in just the right way to reveal the final function.

Once a participant generates a local hypothesis, the next step is to apply the hypothesis to other instances to see if it approximates the desired y values. The basic types of local hypotheses listed in Table 5 do not yield y for any instance other than the one for which they were created. However, a determined participant could test the hypothesis on other instances to examine the discrepancy between the outcome of the hypothesis and the desired y value. Participant 11 applied this technique with the local hypothesis $\{x - 3\}$ by computing $x - 3$ for every instance possible. He then compared the resulting quantity to the desired y -values. This was a helpful exercise because the relation between “ $x - 3$ ” and “ y ” (multiply by x , and divide by 2) is less complicated than that between “ x ” and “ y ” (subtract 3, multiply by x , and divide by 2). By examining the values of “ $x - 3$ ” in comparison to “ y ,” this participant eventually succeeded at discovering the correct solution (see the section on the Local Hypothesis Strategy.)

The second method of generating hypotheses takes information from the activity of Pattern Finding, and *translates* it into an algebraic expression. For example, the quantity “ y differences” in Table 4 can be expressed algebraically as “ $x - 2$.” This process of expressing patterns *in terms of* x allows the participant to use patterns directly in hypotheses because they are thereby represented in algebraic form. Thus, the pattern formerly known as (2 3 4 5) is now equal to $x - 2$, and can be easily included in a hypothesis, for example, $3 * (x - 2) = y$.

Although most hypotheses were generated by one of the two methods just described, occasionally a participant would propose a hypothesis that appeared “in the ballpark” for some reason or other, but which was not otherwise on target. For instance, a participant may have a general theory that the desired function is a quadratic and might therefore propose quadratic functions, one after the other, for testing against the data. This method was not generally successful (indeed, no participant succeeded in solving the problem via this strategy), which is not surprising given the relatively poor use of the data for guidance.

One final point about HG is that we did observe in the participants’ protocols the use of a technique known as “discrepancy analysis.” For example, Participant 11 used

TABLE 6
Proportion of Episodes Devoted to Each Activity

Type of activity	Mean proportion of episodes (SD)		
	All participants (15)	Unsuccessful (6)	Successful (9)
Data Gathering	.25 (.08)	.21 (.05)	.28 (.09)
Pattern Finding	.33 (.18)	.38 (.23)	.29 (.15)
Hypothesis Generation	.35 (.18)	.36 (.25)	.34 (.13)
Other	.09 (.04)	.06 (.06)	.09 (.04)
Mean number of episodes	113	129	102
Range	40–214	85–179	40–214

discrepancy analysis when he tested a hypothesis and then compared its results to the desired y values. This process was shown to distinguish successful from unsuccessful participants in the study by Qin and Simon (1990). Certainly the benefits of discrepancy analysis are straightforward: rather than discarding an incorrect hypothesis and losing whatever information it may embody about the nature of the data and the function being sought, one analyzes the discrepancy between the desired y value and the output of the hypothesis to see how close it comes to the goal. If a participant analyzes a discrepancy as a quantity unto itself and then determines a way to express that quantity in terms of x , the final solution is found. Adding the expression for the discrepancy to the original hypothesis produces the full, final function. In our study we found that both successful and unsuccessful participants used discrepancy analysis, and that the difference in their frequency of use of discrepancy analysis did not reach statistical significance.

The Coordination of DG, PF, and HG

With the identification of these three distinct areas of inductive activity, we have the basis for a comprehensive model of inductive reasoning. To further understand how these three types of activity contribute to the inductive process, we analyzed the proportion of total protocol episodes devoted to each of the three categories of activity. The figures in Table 6 demonstrate that DG and PF do constitute appreciable portions of the inductive process, for both successful and unsuccessful participants. Participants varied greatly in the timing and ordering of their DG activities. However, all participants collected and organized data to test hypotheses, to test that pattern completions were carried out correctly, or to provide more data for analysis. Thus, participants used DG to inform and check PF and HG.

The links between PF and HG, however, are more complex. It is critical to balance efforts between these two areas. Students who focus on HG to the exclusion of PF falter because extreme HG is not effective for inductive reasoning. HG requires the results of PF to inform it, and at the very least (in the case of generate-and-test) to revise it intelligently. Similarly, students who focus too heavily on PF also flounder, because extreme PF amounts to making local sense of the data, but never using that information to form a

global hypothesis. The problem can therefore never be finished because the knowledge gleaned is never expressed algebraically.

Based on these considerations, we hypothesized that successful participants would allocate their effort evenly between PF and HG, whereas unsuccessful participants might allocate their effort in a more lopsided way—either emphasizing PF at the expense of HG, or emphasizing HG at the expense of PF. To test this hypothesis, we calculated a balance score for each participant, by taking the absolute value of the difference between the proportion of episodes spent in PF and the proportion of episodes spent in HG. Low scores on this measure reflect balanced allocation of effort across PF and HG, whereas high scores reflect lopsided allocation.

As predicted, we found that successful participants tended to allocate their effort fairly equally between PF and HG, whereas unsuccessful participants allocated their effort more unequally (*Means* = 21.2 successful, 39.5 unsuccessful, $t(13) = 2.17, p < .05$, 2-tailed). Among the six unsuccessful participants, two spent more than half of their effort in HG, and three participants spent more than half their effort in PF. Of the nine successful participants, only two spent more than half their effort in either HG or PF.⁷ Thus, students who focused on one process at the expense of the other tended to be unsuccessful. These students are reminiscent of novice problem-solvers who repeatedly employed an unsuccessful problem-solving procedure in a study by Novick (1988). Presumably students persevere at these unsuccessful strategies either because they do not know any other strategies to employ, or because they do not have the necessary information with which to employ any other strategies. In contrast, successful participants do not persevere in a single activity, but achieve a kind of ideal: a balance of PF and HG. We turn now to an analysis of these successful participants' solution strategies.

Observed Paths to Success

A total of 3 different paths to solution for F1 and F2 were employed by participants in this study. We discuss them in order of increasing prevalence. Note that the use of the term “strategy” does not necessarily imply here an explicit choice among options.

Recursive Strategy

The least common solution strategy was the Recursive strategy, for which participants translated a method for computing y values recursively into the correct closed-form function hypothesis. The y values for F1 (0, 2, 5, 9, 14, as listed in Figure 4) can be generated using a very simple recursive method. Observe that the difference between the first 2 y values listed (0 and 2) is 2; the difference between the next pair (2 and 5) is 3; and so on. We can thus generate the value for y when $x = 8$ by determining the difference between the y values for $x = 6$ and $x = 7$, which is 14 minus 9, or 5. We increment this value by 1 to get 6, and add 6 to the y value for $x = 7$ to get the y value for $x = 8$. Thus, when $x = 8$, y must be $14 + 6 = 20$. Similarly, when $x = 9$, y must be $20 + 7 = 27$, and when $x = 10$, y is $27 + 8 = 35$.

This method of computing y values is a recursive method because it relies on knowledge of prior y values to generate the current y value. A closed-form method, on the other hand, requires the current value of x , but not any previous values of y . Thus, with a closed-form solution one can generate y values for any x value, no matter how high, without resorting to calculating all of the y values that preceded it.

The two participants who solved F1 via the Recursive strategy began by noting the recursive formula just described. In fact, several participants discovered this piece of knowledge (3 successful and 3 unsuccessful), but then also discovered that they could not use it in the way they wished. The hypothesis that results from this recursive formula is: $y = \text{the previous } y + "x - 2."$ To compute $f(1000)$ using this rule, one needs to know the value for $f(999)$. Not even the most desperate participant attempted this extended calculation. Indeed, at this point most participants abandoned this line of inquiry. Two participants, however, were able to convert this recursive algorithm into a closed-form rule. These two noted that any given y value is the sum of all the y differences that went before it. In other words, the y value when $x = 7$ is equal to $2 + 3 + 4 + 5 = 14$. This sum series always begins at 2 and always ends at $x - 2$ (again, recall the recursive formula). Thus, the problem is simply one of expressing the sum from 2 to $x - 2$. These two participants posed this simpler problem to themselves and were able to retrieve (in one case) or to rederive (in the other) the same formula that Gauss used for the sum of the numbers from 1 to n : namely, $n * (n + 1) \div 2 = \text{the sum of the numbers from 1 to } n$. The two participants applied this formula to the sum from 2 to $x - 2$, and eventually arrived at an algebraic equivalent of $x * (x - 3) \div 2$.⁸ These participants had specialized knowledge that helped them to succeed at this problem and that most likely set them apart from the unsuccessful participants. Indeed, the math background of these two participants was high in relation to the rest of the participants (they reported Math SAT scores of 780 and 710), indicating a likelihood that they would have familiarity with this summation formula and have the algebraic skills to deploy it.

Local Hypothesis Strategy

The Local Hypothesis strategy was used by two participants on F1 and by two participants to solve F2. Thus, it was slightly more common than the Recursive strategy. Every participant, successful or unsuccessful, engaged in the behavior of creating "local hypotheses" to fit a solitary data instance; however, most participants did not rely solely on this strategy to reach the final solution. An example of generating local hypotheses is the following. Suppose that, given an x value of 7 and a y value of 14, we encounter a participant who proposes $\{x + 7 = y\}$ and $\{x * 2 = y\}$ as local hypotheses that work for the particular values of $x = 7$ and $y = 14$. This information, that adding 7 to 7 will result in the desired y value of 14, did not have to be represented in terms of x and y . The participant could merely record that $7 + 7 = 14$, or that $2 * 7 = 14$. In framing these relations in terms of x and y , however, the participant is prepared to test whether this relation holds for other instances. It is this generic capability to apply to other instances that establishes the observed relation as a local hypothesis.

Participant 11 (P11) exemplifies the strategy of producing local hypotheses to generate a promising global hypothesis. When he closely examined the instance (7,14), he already had in mind the notion that $x - 3$ might be involved somewhere [from examining instance (3,0)]. Applying this “minus 3” idea to (7,14) he said:

X equals 7 gives us, Y equals 14. hm. Let's see, now if we think about that, 7 minus 3 equals 4, right? That's if there's minus 3, I might have to drop that idea, but anyways, if there is, multiply that by, so you take, uh, X minus 3, divided by, X times X minus 3, divided by 2? (emphasis added).

The correct rule seems to appear almost effortlessly in a flash of insight. P11 knows that he needs to use x (7), and that he might also use $x - 3$ (4), to produce y (14). He recognizes that 14 factors into $7 * 2$ and he further recognizes that this can be achieved by multiplying 7 and 4, divided by 2. His solution comes largely from examination of this single instance, though it was critical that his prior local hypothesis for instance (3,0) led to the investigation of $x - 3$.

Consider the wide range of possibilities that might otherwise have been proposed! Given the numbers 4 and 14, many avenues exist for relating the two: $4 \text{ plus } 10 = 14$; $4 \text{ times } 2 \text{ plus } 6 = 14$; $4 \text{ plus } 7 \text{ plus } 3 = 14$; $4 \text{ times } 4 \text{ minus } 2 = 14$. Reasonable closed-form rules could have been proposed to correspond with each of these relations: $(x - 3) + 10 = y$; $(x - 3) * 2 + 6 = y$; $(x - 3) + x + 3 = y$; $(x - 3)^2 - 2 = y$; respectively. P11 either avoided considering all these possibilities, or he discarded them instantly, without even having time to verbalize his consideration of them. Why when there are so many equally likely possibilities does he stumble directly onto the *correct* one? The answer lies in his immediate retrieval of the fact that 14 factors into 7 and 2, and his subsequent, probably automatic, retrieval of the fact that 2 is half of 4. With these powerful facts already in mind, the solution that he proposed is *more* attractive than any others expressly because with these facts, he can express every necessary step in terms of x , without any need for further “adjustments” by addition or subtraction. In short, he already has 4 expressed in terms of x : $(x - 3)$. But, as one of the factors of 14, he needs 2 instead of 4, thus, $(x - 3) \div 2$. The other factor, 7, is already set equal to x . Thus, $14 = 7 * 2 = x * (x - 3) \div 2 = y$.

With respect to P11's solution path, it is difficult to overstate the essential role played by the accessibility of arithmetic facts. Without the speedy retrieval of the fact that $14 = 7 * 2$, P11 might have encountered great difficulty in choosing between the many alternatives for relating 4 to 14. Had he chosen a different relation, for example, $14 = 4 * 4 - 2$, then his resulting full formula, $y = (x - 3)^2 - 2$, would not have held for other instances, and he may never have found his way back to the correct relation that he did, in fact, discover.

Participant 15 had to work a little bit harder to produce his Local Hypothesis success story. He actually collected Instance 100: (100, 4850). He was in the habit of factoring the y values for the instances he collected, and did so with this one as well. He broke 4850 down into its prime factors: 2, 5, 5, 97. He then noticed that 97 just so happened to be 100 minus 3 (thus, $x - 3$), so he combined the remaining factors to see how he might also

express them in terms of x . Note that not just any participant would have succeeded with this information. This participant is special, as are all the successful participants, in that he perseveres in attempting to express relations *in terms of* x . He computes $2 * 5 * 5 = 50$ and notes that 50 is half of 100; thus, $x \div 2$. He combines these expressions together, and voila: $(x - 3) * (x \div 2)$, he has the answer.

Like the participants who succeeded via the Recursive strategy, the Local Hypothesis participants also drew on particular background knowledge. However, unlike the Recursive strategy, the knowledge required for the Local Hypothesis strategy is available to the general population: the participants simply required knowledge of arithmetic facts (e.g., $97 = 100 - 3$) and factors (e.g., $14 = 7 * 2$; $2 = 4 \div 2$; $4850 = 97 * 5 * 2 * 2$). What *may* differ between the participants who succeeded via this strategy and others is the swiftness of their access to these facts. Given the speed of certain decisions, it seems that their access to these facts may even have been automatic in certain cases. Thus, speed of access to and accurate retrieval and computation of number facts may have set these participants apart from the others.

Pursuit Strategy

By far, the most common strategy was to reduce the problem to a quantity with an easily recognizable pattern. We call this the Pursuit strategy because it requires that the participant *pursue* a line of inquiry through several steps: (1) identification of a pattern in a quantity q ; (2) pursuit of q as a subgoal to understanding y ; (3) expression of q in terms of x ; (4) combination of expressions into a global formula. For F1, the specifics are as follows. In the course of standard Pattern Finding procedures, the participant looks for a number to answer the query, “ x times *what* equals y ?” If the participant answers this question for enough instances, then she may be able to detect the fact that this quantity (q) increases by $1/2$ with each increase in the value of x . Having identified this pattern, the participant must make the decision whether or not to pursue this line of inquiry further. If she decides to do so, the next step is to try to understand the relationship between x and this new quantity q . Ideally, this attempt will eventually result in the discovery of an algebraic expression that concretely specifies the relation between x and q (i.e., $(x - 3)/2 = q$). With such an expression in hand, the participant now has the answer to the question “ x times *what* equals y ?,” and can thus multiply by x to complete the full formula: $x * (x - 3)/2 = y$.

Five of the 9 successful participants on F1 employed this strategy, as did 13 of the 15 successful participants on F2, for a total of 18 out of 24 successes (75%), or 18 out of a total of 32 attempts (56%). Because it was the most common strategy, we provide a walk-through example of this strategy, with highlights from one successful participant’s protocol.

One Student’s Solution to F1. What follows is a detailed examination of the critical steps taken by one successful participant, “Ace.” (The full text of Ace’s verbal protocol, divided into segments by carriage returns, appears in Appendix B. His written work

TABLE 7
Data Instances in Order Collected by Ace

Variable	Instance number									
	1st	2nd	3rd	4th	5th	6th	7th	8th	9th	10th
x	10	2	3	50	5	25	4	6	7	15
y	35	—	0	1175	5	275	2	9	14	90

appears in Appendix C.) Ace does not begin by generating instances in any regular sequence. He collects them in the order shown in Table 7.

Ace reorganizes this data before collecting $x = 6$, so that the smaller x values (3, 4, 5) are sequential, and then collects $x = 6$ and $x = 7$ and records them into a table like that seen in Figure 5.1. Figure 5 displays an overview of Ace’s solution path from this point forward. Each step is numbered (step numbers are circled) and outlined by a box. Where one quantity has been computed in two different steps, inner boxes are used to denote the separate steps.

1. After some initial struggling (see protocol, Appendix B, lines 1–107), Ace reorganizes the data so that it looks like the table seen in Figure 5.1.
2. Ace then computes the differences between the successive values of y (lines 109–112):
 “0 to 2, is jump of 2,
 2 to 5, jump of 3,
 5 to 9, jump of 4,
 9 to 14 is a jump of 5”
3. In examining these “ y differences,” Ace notices a relation between the column of x values and the y differences (lines 115–118):
 “ $X, \dots X$ minus 2

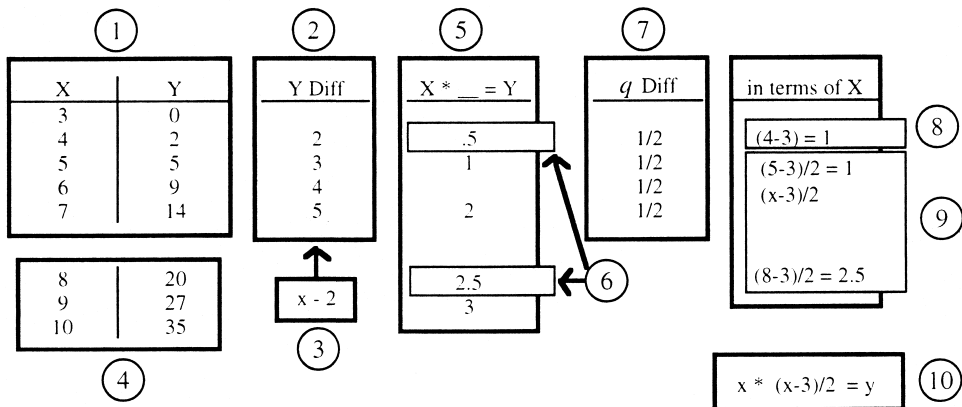

Figure 5. Overview of Ace’s solution path.

is the increment of that jump.
from the number before.”

The formula “ $x - 2$ ” characterizes the increment from one y value to the next. Thus, when x equals 6, $x - 2 = 4$, which is indeed the difference between the corresponding y value of 9 and the previous y value of 5.

4. Using this recursive rule (computationally equivalent to $y_n = y_{n-1} + (x_n - 2)$) Ace extrapolates to the instances where $x = 8$ and $x = 9$, and finally confirms the formula by producing from it the correct y value to correspond with $x = 10$ (an instance he had already collected) (lines 121–130).

“ X minus 2 is the increment
would be . . . 6 . . . 8
make it 20
so there’s 9
make it 27
there’s 10
you make 35.
figured that out.”

5. Ace realizes the limitations of his recursive formula. To find the value of this function when $x = 1000$, he would need to know the value of the function when $x = 999$, and so on (lines 131–150). He thus tries to find a way to predict y from x that does not require knowledge of the previous y value (lines 151–162). (This is the point at which the Recursive strategy diverges.) He is searching for a relation between x and y that remains true for several instances. He notes that for the instances 5, 7, and 9, x can be multiplied by an integer to produce the appropriate value of y (lines 163–165).

“ 7 times 2 is 14.
9 times 3 is 27
5 times 1 is 5.”

6. Ace notices that the quantity being multiplied (1, 2, 3), called q here, is increasing by 1. (He tests this with the pair (11,14).) However, he is only looking at every other x value (5, 7, 9, 11). Given this information, he guesses that q when $x = 8$ might be 2.5, the number exactly between the values of q for 7 and 9 (lines 179–185). After testing that 8 times 2.5 does equal the desired y value of 20, Ace also notes that $q = 0.5$ works when $x = 4$ (lines 179–200).

“ 8 times 2.5,
what’s that equal? . . .
yeah that’s it. . . .
yeah, because 4 times 0.5 is 2”

The value q that Ace has discovered is actually equal to y/x . Use of this new quantity is a critical step in the solution.

7. Having written down instances of this intermediate quantity q , Ace notices that they increase by 0.5 with each increase of 1 in the value of x (lines 202–211).

“ Y equals X times 0.5 for 4

Y equals X times 1 for 5
and goes up by 0.5 each time. . . .
after 3 it goes up by 0.5 each time.”

8. Ace now tries to find a relation that will “generically” specify how q increases by 0.5 with each increase of x (lines 217–235):

“trying to see
how you move the 0.5 up every time, generically. . . .
I can’t figure out a way to make it go up with the X.
Y equals X times,
how do I get that 0.5
would be 4 minus 3”

The relation that Ace discovers between x and q (“would be . . . 4 minus 3”) is actually a relation between x and the *numerator* of q , which we call q_2 . The value of q for $x = 4$ is 0.5, or $1/2$. Subtracting 3 from x we get $4 - 3 = 1$, which is q_2 : the numerator of $1/2$.

9. Ace examines another instance ($x = 5$) and determines that the relation between $x - 3$ and q_2 continues to hold. For this instance, he goes a step further, and divides the numerator by 2 to get the actual q value of 1 (lines 238–241):

“ 5 minus 3 divided by 2
get us the 1
so that would be
X minus 3 divided by 2”

Ace has taken the crucial step at this point of expressing *in terms of x* the relationship between the quantities x and q that he has found to hold for the single instance $x = 5$. This general expression $(x - 3) \div 2$ will allow him to apply his new discovery to many other instances.

He tests this new formula with other instances (lines 242–246):

“try 4 minus 3 divided by 2
that’s. . . 0.5
try 8 minus 3 divided by 2
that equals the 2.5 that we need”

10. Finally satisfied that his partial formula $(x - 3) \div 2$ for yielding q is accurate, Ace multiplies this partial formula by x to produce a full hypothesis (lines 247–250):

“so we have
Y equals X times
X minus 3
divided by 2.”

Ace’s solution can be summarized as follows: find for several instances the values that, when multiplied by x , yield y (step 5, Figure 5). We call these new values q . Look for a pattern within q and discover that q increases by $1/2$ for each increment of 1 in x (step 7, Figure 5). Having discovered a pattern that holds for all values of x , aim to express q

solely in terms of x . In this way the new quantity is viewed as something to be investigated in its own right, or to be *pursued*. The original goal was to express y in terms of x . A subgoal has now been established to express q in terms of x . Pursue this subgoal by looking for patterns in (x, q) instances. Ace pursues a *further* subgoal (step 8, Figure 5) by determining the relationship between x and q^2 , the numerator of q . Having determined this relationship, he returns to the prior subgoal of expressing the pattern in q in terms of x (i.e., $(x - 3)/2 = q$) (step 9, Figure 5). Recall that q was created because it could be multiplied by x to produce y . Thus, we multiply the formula for q by x , and thereby produce a full formula for expressing y in terms of x (step 10, Figure 5).

In focusing on the relation between x and certain intermediate quantities related to y (i.e., q and q^2), Ace reduced the complexity of the problem he was solving: the relation between x and y/x (subtract 3, and divide by 2) is less complicated than that between x and y (subtract 3, multiply by x , and divide by 2); and the relationship between x and q^2 (subtract 3) is less complicated than that between x and q (subtract 3, and divide by 2). In fact, Ace reduced the problem to such an extent that he determined the nature of a one-operator relationship between x and another variable before he began to build back up to the full hypothesis. It is useful to note here that Ace went beyond reducing the problem to one of a *linear* relationship between x and another variable (which *is* the nature of the relationship between x and q). F1 is a quadratic function, whereas q is a *linear* function of x (albeit a nonprototypical one: $(x - 3)/2$). Discovery of this linear relation would have been sufficient cause for the BACON model to finish this problem. However, Ace's pursuit of the relation between q and x (which is linear, but encompasses *two* operators) led to examination of the relationship between x and the numerator of q (which is linear and has only *one* operator). Thus, the virtue of pursuing intermediate quantities, like q and q^2 , is not specifically about reducing a quadratic function to a linear one, but more generally about reducing the complexity of the problem to the point where a pattern becomes recognizable and is simple enough to be readily expressed in terms of x .

The Importance of Pursuit

Pursuit encompasses the following five activities. (1) Detect a pattern in a quantity q . (2) Decide that this pattern is worth pursuing. (3) Investigate the quantity q as you would y , applying DG, PF, and HG tools. (4) Express q in terms of x . (5) Build on the algebraic expression for q to propose a full hypothesis. Note that step 2 promotes recursion. In other words, in the process of investigating q , the participant may happen upon an additional quantity, say q^2 , that further simplifies the problem and that itself then merits Pursuit (e.g., in Ace's solution path, the numerator of the quantity y/x). This q^2 would thus be expressed in terms of x (just as Ace found the expression $x - 3$ was equal to the numerator of y/x) as a stepping stone to expressing q in terms of x . Expressing q in terms of x would, in turn, be a stepping stone to expressing the full rule in terms of x . Successful participants did all of these steps of Pursuit. Unsuccessful participants who took the first steps of the Pursuit strategy did not see it through all of these steps. In this section we discuss how unsuccessful participants failed in their Pursuit.

TABLE 8
Comparison of Unsuccessful and Successful Pursuit on F1

Step achieved	Unsuccessful	Successful	Fisher's exact p -value
Computed q	4/6	6/9	.42
For at least 3 instances	3/4	6/6	.40
At regular intervals	2/4	6/6	.13
Detected q pattern	1/4	5/6	.11
Tried to express q in terms of x	0/4	5/6	.02
Solved the problem via Pursuit	NA	5	—

The Pursuit strategy for F1 involved the quantity $q = y/x$. Ten participants created this quantity: 6 successful and 4 unsuccessful. (Table 8 lists the number of unsuccessful and successful participants who made it to each step of the Pursuit process. Also included are the p -values for whether or not the difference between the number of unsuccessful and the number of successful participants reaching each step is statistically significant.) Nine of these participants computed q for *enough* instances to distinguish a linear pattern in the quantity. The one participant who did not was unsuccessful. Eight participants computed q for instances that were equidistant from one another, and which therefore facilitated the detection of the linear pattern in q . The participants who did not were unsuccessful.

To look for a pattern within q , or to produce any new quantities deriving from q , a participant has to regard q as a new problem unto itself: a new “ y ” to subject to analysis with all the tools in their inductive, pattern-finding toolbox. The heuristic of investigating and analyzing a newly created quantity in its own right is the cornerstone of Pursuit. Ace pursued q . He: (1) detected and investigated a pattern in q which eventually allowed him to (2) express q solely in terms of x . Of the 8 participants who computed q for enough instances in F1, only 6 of them detected the pattern in q that Ace did (Figure 5, step 7).⁹ Of the two participants who did not detect this pattern, one was unsuccessful, and one eventually went on to solve the problem via the Recursive strategy.

Finally, q cannot contribute to a participants' final solution unless it is expressible solely in terms of x and can thereby be used as part of a formal algebraic formula. Of the 6 participants remaining in the Pursuit game at this point, only one did *not* attempt to express that pattern in terms of x . This participant was unsuccessful. All 5 remaining participants *did* attempt and succeed at expressing this pattern in terms of x , and from there proceeded to solve the problem.

Thus, at each step of the way, unsuccessful participants could and did abandon the Pursuit strategy. In fact, every unsuccessful participant failed to persevere to the point of even expressing q in terms of x , and did not even encounter the problem of constructing a final hypothesis based on the algebraic expression for q .

Puzzle Pieces and Expression in Terms of X

The final step of Pursuit is to build a full hypothesis based on the fruits of one's prior investigations. These algebraic expressions of patterns are like puzzle pieces: each must

TABLE 9
Acquisition of Puzzle Pieces

Puzzle piece	Unsuccessful	Successful	Fisher's exact <i>p</i> -value
$x - 3$	6/6	9/9	1.0
x^*	4/6	9/9	.14
$\div 2$	1/6	9/9	<.01
$(x - 3)/2$	1/6	9/9	<.01
$x/2$	2/6	9/9	.01
$x(x - 3)$	1/6	9/9	<.01

be fit into the final formula in just the right way to produce the final product. The algebraic formula that expresses q in terms of x , namely, $q = (x - 3)/2$, is composed of two puzzle pieces that have been pieced together. Recall how Ace constructed his final hypothesis one piece at a time. He first reduced the problem to the discovery of the relation between x and q , and thus introduced the notion that “* x ” would be a component of the final function (because $x * q$ would equal y). He then discovered the relation between x and the numerator of q : “ $x - 3$.” Finally he included the component of dividing $x - 3$ by 2, and, in combining all these pieces together: “* x ,” “ $x - 3$,” and “ $\div 2$,” he produced his final hypothesis. These individual components of F1 could be thought of as puzzle pieces that need to be fit together to construct the correct rule.

Could it be that one or another of these pieces was particularly elusive to the unsuccessful participants? Or was it the composition of the pieces that posed the real challenge? For each unsuccessful participant, we coded whether each of these 3 pieces of the F1 “puzzle” or any of their 2-piece combinations were considered at any point during the protocol (see Table 9). All but the “ $x - 3$ ” and the “* x ” puzzle pieces reveal statistically significant differences between successful and unsuccessful participants. Thus, unsuccessful participants did not discover individual necessary components of the function. This result leaves open the possibility that unsuccessful participants are as capable as successful participants at *recombining* the puzzle piece elements to form the final function, if only they have these elements on hand. Achieving these puzzle pieces, of course, requires expressing a quantity in terms of x .

As seen in Table 8, expressing a pattern in terms of x seems to have been a major stumbling block for unsuccessful participants. It is a step of Pursuit that no unsuccessful participant completed. Furthermore, expressing a pattern in terms of x is the process by which participants create puzzle pieces for fitting the final hypothesis together. Thus, it is not terribly surprising that Table 9 shows that unsuccessful participants also had difficulty with discovering the correct puzzle pieces.

How did successful participants express patterns in terms of x ? Ace provides an example in his step 9. Here is an example from another successful participant:

P7: “let’s see how can we relate the number, the initial number to the denominator, . . . 8 goes to 5, that’s minus 3, 10 goes to 7, that’s minus 3, . . . alright, so maybe the denominator is [x] minus 3.” (lines 735–750; note: this participant was trying to express x/y , the reciprocal of q .)

By contrast, here is the excerpt from the protocol of the one unsuccessful participant who did get as far as detecting the pattern in q , but who did not succeed in expressing q in terms of x . This excerpt begins with the participant listing the values of $(y - x)/x$ for instances 10, 9, 8, 7, and 6, respectively. (This participant was trying to express $(y - x)/x$, rather than y/x):

P8: 2.5, 2, 1.5, 1, 0.5, um, 0.5 um, x plus 0.5x, x plus x, x plus 1.5x, x um, so if x every time, add 0.5, x, plus 3, times, x plus, 3, 3x, um, 1.0x, um, x plus 0.5x, x plus 1.0x, y, um, y, y plus 3?, y, y minus, divided by 3?, um, 6 plus 3 is 9, x plus, 7 plus 7 is 14, is 2, 2.5, 1.5, um, x plus 0.5, x, 1, 1.5, x plus 0x?, x plus negative 0.5x. . .

Note that although P8 detects the pattern that $(y - x)/x$ is increasing by 0.5, she does not attempt to express the sequence of numbers 0.5, 1, 1.5, 2, 2.5 in terms of x^{10} (which would result in the expression $(x - 5)/2$), but instead simply inserts these y -derived values into instance-specific formulas: for Instance 6: $x + 0.5x = y$, for Instance 7: $x + 1x = y$, and so forth. Without a general characterization of the values 0.5, 1, 1.5, 2, 2.5 to insert into these instance-specific formulas, she cannot move closer to her goal of finding a general hypothesis. She soon returns to expressing these instance-specific formulas in their original, number-specific forms: $6 + 3 = 9$, $7 + 7 = 14$, only to return again to the futile effort of expressing these individual formulas in terms of x : for Instances 5 and 6: “x plus 0x?, x plus negative 0.5x.”

Summary of Successful Strategies

The three strategies to success, Recursive, Local Hypothesis, and Pursuit, share certain elements. Perseverance and the goal to express relations in terms of x are essential to all. Further, each strategy relied on mathematical background knowledge, particularly pattern recognition knowledge for relations between particular numbers. In our computer model of inductive problem solving, we have tried to capture the essential elements of the successful Pursuit strategy.

The PURSUIT Model

Based on the protocol data described above, we developed a cognitive model of participants' performance, to further articulate our theory of inductive reasoning. We chose to simulate the Pursuit strategy because it was the strategy used most often. Our theory of the cognitive processes involved in Pursuit includes the following activities: (1) Detect patterns by examining the data; (2) Create new quantities; (3) Express patterns in terms of x ; (4) Construct hypotheses; and (5) Test hypotheses. We developed a production system model called PURSUIT, based in ACT (Anderson, 1993), to simulate these processes. Data collection and organization strategies are not addressed in the PURSUIT model (the data are already “collected” and organized into an ordered table when PURSUIT begins the problem.)

In the PURSUIT model, quantities are represented as lists of values, and hypotheses store a conjectured algebraic relationship between two quantities. The model starts with the

TABLE 10
PURSUIT Productions

Area of activity	Process	PURSUIT productions
Pattern Finding	Detect a pattern	Recognize-pattern, Examine-numerator
	Create a new quantity	Relate-by-addition, Relate-by-subtraction, Relate-by-multiplication, Find-differences-within-quantity
Hypothesis Generation	Express pattern in terms of x	Express-in-terms-of-X
	Construct hypothesis	Unwind-multiplication, Unwind-subtraction, Unwind-division
	Test hypothesis	Test-hypothesis, Finish

quantities x and y , corresponding to the list of x and y values given in the problem, and without any hypotheses. During problem solving, the PURSUIT model creates new intermediate quantities, like q and $q2$ in the example of Ace above, and generates new hypotheses.

The procedural knowledge in PURSUIT is represented in if-then production rules. For example, the following is an English version of PURSUIT's knowledge of how to find the multiplicative relation between two quantities: "If the goal is to find a relationship between the source quantity, S , and the pursuit quantity, P , Then for each instance of S and P find the value you need to multiply S by to get P , and create a new quantity that contains these values." For a complete list of the English versions of PURSUIT's productions, see Appendix D.

In the PURSUIT model, x is designated as the original "source" quantity from which we want to be able to compute y , and y is designated as the original "pursuit" quantity, which we want to be able to compute, given x . Before it pursues any quantity other than y , the PURSUIT model establishes that said quantity is worthy of pursuit by assessing whether the quantity contains a recognizable pattern. When the model encounters a quantity that does not contain a pattern that it recognizes, the model returns to focusing on previous pursuit quantities.

Pattern Finding Productions

PURSUIT has productions for both Pattern Finding and Hypothesis Generation activities (see Table 10). The PF activities observed in the protocols of all participants are encapsulated in the following PURSUIT productions: Relate-by-addition, Relate-by-subtraction, Relate-by-multiplication, Find-differences-within-quantity, Examine-numerator, and Recognize-pattern. The "Relate-by" productions examine the arithmetical relations between the source quantity (i.e., x) and the pursuit quantity (e.g., y). These productions can be thought of as a kind of discrepancy analysis (Qin & Simon, 1990), or as a way to compute the difference between a pursuit quantity, such as y/x , and x itself when searching for a way to express a quantity in terms of x . Thus, Relate-by-subtraction would compute the difference between the x value and y value in each (x,y) pair. The Find-differences-within-

quantity production creates the “y differences” quantity that we encountered in Table 4 and in Ace’s step 2, and the Examine-numerator production allows the model to examine the top half of a series of fractions, something that the human eye can do with relative ease. The ultimate goal of PF, of course, is to actually detect a pattern. This crucial step is accomplished (or not) by the Recognize-pattern production. This production is supplied with a small list of patterns that it recognizes instantly: the counting numbers, the odd numbers, and the even numbers. With these PF productions, the PURSUIT model can create all of the quantities created by participants on F1, as listed in Table 4.

Hypothesis Generation Productions

PURSUIT’s HG productions are: Express-in-terms-of-X, Unwind-subtraction, Unwind-multiplication, Unwind-division, Test-hypothesis, and Finish. The most crucial of these HG productions is Express-in-terms-of-X. This production fires whenever a relationship between the source quantity (i.e., x) and the pursuit quantity, P , has been found which requires only the adding, subtracting, multiplying, or dividing of some constant to produce P from x (e.g., $x - 3 = P$). In other words, this production fires when the relationship being pursued is a single-operator relationship. It is with this production that the process of building a hypothesis arises from the fruits of Pattern Finding. Once an initial algebraic expression has been created from this production, the other HG productions can fire. The “Unwind” productions reverse the PF computations that produced the final pursuit quantity, recombining the puzzle pieces found along the way so that the hypothesis will eventually yield the original pursuit quantity, y . Finally, the Test-hypothesis and Finish productions test that the final hypothesis holds for several instances and then declare the problem solved.

Pursuit’s Successful Performance on F1

For F1, PURSUIT is provided with the quantities x (3 4 5 6 7) and y (0 2 5 9 14). Table 11 summarizes the sequence of productions used by the PURSUIT model to solve F1, as well as the corresponding changes to the model’s knowledge. A possible first step the model can take is to fire the “Relate-by-multiplication” production. This production produces a new quantity that we called q in Ace’s protocol, but that we will refer to here as $A = y/x$ to indicate how it relates to x and y . In the second step (#2 in Table 11), the Recognize-pattern production examines A to determine whether it matches any patterns in the model’s repertoire of pattern recognition. If the quantity matches a known pattern, it is designated worthy of further pursuit. It is at this crucial point in the problem that the PURSUIT model uses its repertoire of pattern knowledge to decide that the quantity A is worthy of further pursuit. For the model to make this decision, as did the successful participants, we have included in its pattern recognition repertoire the knowledge to recognize the pattern in A , which is that the quantity increases by $1/2$ with each successive

TABLE 11
PURSUIT Productions for Succeeding at F1

Production	Action	New knowledge	Quantities	Compare to
1. Relate-by-multiplication	$S * _ = P$	$A = (0\ 1/2\ 1\ 3/2\ 2)$	$A = Y/X$	Ace's step 5.
2. Recognize-pattern: <i>differs-by-halves</i>		Pursue A		Ace's step 7.
3. Examine-numerator		$B = (0\ 1\ 2\ 3\ 4)$	$B = 2A = 2*Y/X$	
4. Recognize-pattern: <i>counting-numbers</i>		Pursue B		
5. Relate-by-subtraction	$S - _ = P$	$X - B = (3\ 3\ 3\ 3\ 3)$		
6. Express-in-terms-of-X	$Hypo \Rightarrow P$	$(X - 3) = B$		Ace's step 8.
7. Unwind-multiplication	Hypo/2	$(X - 3)/2 = A$	$B/2 = A$	Ace's step 9.
8. Unwind-division	(Hypo)*X	$X*((X - 3)/2) = Y$	$A*X = Y$	Ace's step 10.
9. Test-hypothesis		$X*((X - 3)/2) = Y$		
10. Finish		Problem F1: Status = solved.		

value of x . Thus, the Recognize-pattern production recognizes the pattern in A and designates A for further pursuit.

In Step 3, the Examine-numerator production multiplies A by its constant denominator so that the model may investigate the numerator alone (the quantity which we referred to as q_2 in Ace's protocol, but which we refer to here as B). At this point (step 4), the model recognizes a pattern in B : the values $(0\ 1\ 2\ 3\ 4)$ match the production's template for the counting-numbers. Thus, the quantity B , in $y = x * B/2$, is designated as the new pursuit quantity. As such, the model now begins to investigate ways in which the source quantity, x , might be related to this new pursuit quantity, B . The model succeeds in relating these two quantities by subtraction (step 5) and the result is a constant difference of 3. At this point, the Express-in-terms-of- X production fires because the source quantity x and the pursuit quantity P differ by only a constant. The model thus produces its first algebraic expression: $x - 3 = B$.

A pursuit quantity, B , has now been expressed in terms of the source quantity, x . The connection from x to y has been made. What remains is to reconstruct the steps taken to get to B so that we may express y in terms of x . B was created by dividing the previous pursuit quantity, A , by 2. The Unwind-multiplication production (step 7) reverses this step and divides the new algebraic expression $\{x - 3\}$ by 2. The model now has an algebraic expression $\{(x - 3)/2\}$ for the pursuit quantity A . However, A was created to yield y when multiplied by x . Thus, the Unwind-division production fires and multiplies by x our expression for A , thus creating a full expression for y . Finally, the Test-hypothesis production fires and determines that this algebraic expression for y does hold for several instances, and the Finish production fires, declaring the problem solved.

We already noted the important role played by the Recognize-pattern production in this solution. For this production to recognize the counting numbers (i.e., recognize any portion of the sequence $1\ 2\ 3\ 4\ 5\ \dots$) is not terribly controversial, as even the most rudimentary math education allows for this competence. The ability to recognize differs-by-halves, however, is more subtle, especially because participants' initial representations

TABLE 12
PURSUIT Productions for Failing at F1

Production	Action	New knowledge	Quantities	Compare to
1. Relate-by-multiplication Cannot fire "Recognize-pattern"	$S^* _ = P$	$A = (0 \ 1/2 \ 1 \ 3/2 \ 2)$	$A = Y/X$	Ace's step 5
2. Relate-by-subtraction Cannot fire "Recognize-pattern"	$S - _ = P$	$C = (-3 \ -2 \ 0 \ 3 \ 7)$	$C = Y - X$	
3. Find-differences-within-quantity		$D = (_ \ 2 \ 3 \ 4 \ 5)$	$D = Ydiff$	Ace's step 2
4. Recognize-pattern: <i>counting-numbers</i>		Pursue D		
5. Relate-by-subtraction	$S - _ = P$	$X - D = (_ \ 2 \ 2 \ 2 \ 2)$		
6. Express-in-terms-of-X Cannot fire "Unwind" productions IMPASSE	Hypo = P	$(X - 2) = D$		Ace's step 3 Ace's step 5

of the quantity A are generally 1, 1.5, 2, 2.5, . . . or $1, 1\frac{1}{2}, 2, 2\frac{1}{2}, . . .$, rather than 1.0, 1.5, 2.0, 2.5, . . . or $2/2, 3/2, 4/2, 5/2, . . .$. Recall that some unsuccessful participants did have the data for y/x , yet they did not pursue this useful quantity. Our theory is that the unsuccessful participants did not pursue y/x because they did not recognize the pattern within it and, therefore, did not recognize the quantity as simpler than y itself.¹¹ Thus, they abandoned this path as not likely to be productive.

PURSUIT Unsuccessful Performance on F1

If the PURSUIT model has an appropriate and accurate decomposition of knowledge it should be able to capture individual differences in participant performance. We demonstrate PURSUIT's accuracy by showing how the model captures the performance of unsuccessful participants. To simulate unsuccessful performance on F1, the differs-by-halves pattern is removed from the list of familiar patterns for the Recognize-pattern production. Impaired in this way, the PURSUIT model computes several quantities that compare x and y , including Relate-by-multiplication (which yields $A = y/x$), Relate-by-subtraction (which yields $C = y - x$), and Find-differences-within-quantity (which yields $D = y$ differences). One possible path is shown in Table 12. The only one of these new quantities that is recognized by the Recognize-pattern production is D, which has the values (2, 3, 4, 5): the counting numbers. The model recognizes these y differences as a pursuit quantity, and therefore may apply Find-differences-within-quantity again, or Relate-by-subtraction, with x as the source quantity and D as the pursuit quantity.

PURSUIT does apply Relate-by-subtraction (step 5 in Table 12) with the result that x and D differ by a constant value of 2. At this point, the Express-in-terms-of-X production fires and produces the algebraic expression that $(x - 2) = y$ differences. PURSUIT would now apply further HG productions if any of them applied, but the within-quantity difference operation that produced the y differences quantity is not reversible algebraically. Thus, PURSUIT reaches an impasse.

Note that our successful participant Ace also reached this impasse. The steps taken by the unsuccessful PURSUIT model are mirrored in Ace's steps 2 and 3. However, the only formula that could arise out of this $(x - 2) = y$ differences expression is a recursive one:

$$f(x) = (x - 2) + \text{the previous } y \text{ value.}$$

This is not a closed-form algebraic function, and, like Ace and like most participants, the PURSUIT model cannot produce a closed-form solution from the recursive formula. When participants, both successful and unsuccessful, arrived at this impasse (in total, 6 participants: 3 successful and 3 unsuccessful) they generally scrapped what they had found and began again with the original x and y (with the exception of the two participants who succeeded with the Recursive strategy, as previously described).

Thus, the model arrives at an impasse when it attempts to solve F1 without the ability to recognize the differs-by-halves pattern in y/x . As such, we do not need to assume that unsuccessful participants are incapable of producing y/x to explain their failure at discovering F1. This is an important point. Prior work in this domain (Huesmann & Cheng, 1973; Gerwin & Newsted, 1977) maintained that functions involving division pose particular difficulty for students trying to induce them. Our model suggests that this difficulty is not due to an inability to use or to conceive of using division, but rather to a failure to recognize when division has led to a simplification of the problem. Quantities resulting from division often involve fractions or decimals, rather than whole numbers, and such quantities may be difficult to recognize as problem simplifications. Our data show that unsuccessful participants did consider division and were capable of performing division, and these skills are thus intact in the unsuccessful model. The thing that is impaired is the ability to recognize a certain pattern. Note that the PURSUIT model's simulation of unsuccessful performance also does not necessitate the removal of the fundamental idea of pursuing and analyzing a new quantity just as if it were the original y quantity. It is knowing *what* to pursue that differentiates the successful and unsuccessful outcomes. Indeed, our model indicates that limited numerical pattern recognition knowledge is the critical distinguishing feature of unsuccessful performance.

PURSUIT'S Successful Performance on F2

Given that the PURSUIT model accounts for both successful and unsuccessful performance on F1, can both these versions of the model also succeed at F2? It is a crucial test for the validity of our model to determine whether it can account for the failure of unsuccessful participants on F1 as well as their overwhelming success in finding F2. Fifteen of the 16 participants succeeded at finding F2; only one participant failed, and this one also failed at F1. Of those who succeeded on F2, 13 did so via the Pursuit strategy and calculation of y/x (the other two, both of whom were successful on F1, succeeded via the Local Hypothesis strategy). The PURSUIT model simulates this common Pursuit strategy for solving F2 via the computation of y/x . Table 13 lists the productions that fire to solve F2.

TABLE 13
PURSUIT Productions for Solving F2

Production	Action	New knowledge	Quantities
1. Relate-by-multiplication	$S * _ = P$	$A = (3\ 5\ 7\ 9\ 11)$	$A = Y/X$
2. Recognize-pattern: <i>odd-numbers</i>		Pursue A	
3. Relate-by-addition	$S + _ = P$	$B = (2\ 3\ 4\ 5\ 6)$	$B = A - X = Y/X - X$
4. Recognize-pattern: <i>counting-numbers</i>		Pursue B	
5. Relate-by-addition	$S + _ = P$	$B - X = (1\ 1\ 1\ 1\ 1)$	
6. Express-in-terms-of-X	$Hypo \Rightarrow P$	$(X + 1) = B$	
7. Unwind-subtraction	$Hypo + X$	$X + (X + 1) = A$	$B + X = A$
8. Unwind-division	$(Hypo)*X$	$X*(2X + 1) = Y$	
9. Test-hypothesis		$X*(2X + 1) = Y$	
10. Finish		Problem F2: Status = solved.	

For F2, PURSUIT is provided with the quantities x (1 2 3 4 5) and y (3 10 21 36 55). The Relate-by-multiplication production fires first. This production produces the quantity $A = y/x$. In step 2 the Recognize-pattern production examines A (3, 5, 7, . . .) and finds that it matches the odd-numbers template. A is thus marked a pursuit quantity and the model begins to investigate patterns and relations between x and A . In the third step, the model relates x and A by addition, so that the quantity $B = A - x$ is created. Once again, the Recognize-pattern production fires, this time recognizing the quantity B (2, 3, 4, . . .) as matching the counting numbers. PURSUIT now looks for a relation between x and the new pursuit quantity, B . The Relate-by-addition production finds that the corresponding values for B and x differ by a constant value of 1. At this point, Express-in-terms-of- X fires and produces the algebraic expression: $x + 1 = B$. To reconstruct the steps taken to get to B , the Unwind-subtraction and Unwind-division productions fire (steps 7 and 8). The resulting hypothesis is $x * (2x + 1) = y$, and the problem has been solved.

Although this solution path is very similar to the solution for F1, participants who used this strategy successfully on F2 did not succeed in following the same strategy to solution for F1. For the model, the only difference between successful and unsuccessful performance on F1 is the ability to detect the differs-by-halves pattern in y/x . For the solution to F2, this pattern does not play a role, and so the full and the impaired versions of PURSUIT from F1 perform identically to solve F2.

Model Summary

Thus, the PURSUIT model, endowed with Pattern Finding and Hypothesis Generating productions, accounts for both successful and unsuccessful performance on F1, as well as success on F2. One key finding is that the adjustment needed to produce success versus failure on F1 is *not* an adjustment of procedural knowledge. PURSUIT’s model of unsuccessful performance contains all the same productions as the successful model, just as the

unsuccessful participants in this study engaged in the same PF and HG behaviors as did the successful participants. Instead, it is pattern recognition knowledge that differentiates the full and impaired versions of the PURSUIT model.

The difference in declarative knowledge between the successful and impaired model was a difference in the types of patterns that the model recognized. The successful version recognizes that successive values of a particular quantity increase by one-half. It pursues the quantity containing that pattern, and ultimately discovers the complete hypothesis. The impaired version of the model does not recognize this pattern, and consequently does not pursue the simpler quantity, and is unable to construct the final hypothesis. Thus, a small difference in pattern finding accounts for the difference between success and failure on F1. In this way, the model demonstrates that pattern finding plays an essential role in inductive reasoning.

IV. DISCUSSION

This study has revealed some crucial processes involved in inductive reasoning, a skill which is required in both mathematics and science, and which plays a role in problem-solving performance, learning, and the development of expertise (Holland et al., 1986; Pellegrino & Glaser, 1982; Simon & Lea, 1974; Egan & Greeno, 1974; Chi et al., 1982). Indeed, inductive learning methods aid the acquisition of problem-solving knowledge even in problem domains that appear deductive on the surface (Johnson-Laird, 1983; Koedinger & Anderson, 1989, 1998). Furthermore, induction has recently been targeted as an important educational objective in math education (NCTM, 1989; Serra, 1989); although a detailed understanding of the cognitive processes that support inductive reasoning is still lacking. The current investigation was designed to advance our understanding of the cognitive skills required for inductive reasoning in mathematics.

In this investigation, we assessed inductive reasoning using function-finding tasks. These tasks are representative of inductive reasoning tasks in that they require several of the processes identified by Klauer (1996) as central to inductive reasoning. Specifically, function-finding tasks require detecting and characterizing both similarities and differences in the relationships between successive pairs of numbers. The function-finding task is also representative of inductive reasoning in mathematics, because the problem of finding functions from data is fundamental to many areas of mathematics. Mathematicians and scientists use function finding when searching for a rule or theory to describe a set of data. Function-finding problems are also embedded in domains in which numbers do not appear on the surface (e.g., the geometry example in Figure 2), and can also arise to aid in the recall of formulas or procedures (e.g., the combinatorics example in Table 3). Thus, function finding is important in a wide variety of mathematical endeavors.

We wished to investigate the inductive reasoning processes used by nonexpert but intelligent problem solvers, so we chose undergraduate students as our participant population. By presenting function-finding problems to intelligent novices — nonexperts who nevertheless have the general strategies and knowledge to be successful in novel situations

— we attempted to ensure that the reasoning processes we observed would indeed be inductive.

Empirical Summary

This study identified three basic activities involved in inductive reasoning that students engage in to solve function-finding problems: Data Gathering, Pattern Finding, and Hypothesis Generation. We identified DG as an important process that is more variable and less structured than has been implied in the literature, and we demonstrated that successful and unsuccessful students collect comparable data instances and organize data with comparable skill. In this study, DG did not differentiate successful from unsuccessful performance. Successful and unsuccessful students did differ in how they used PF and HG. Students who did not succeed at solving the problems tended to allocate the majority of their effort to either PF or to HG, and did not use PF to inform HG or vice versa. In contrast, successful students allocated their effort evenly across PF and HG and integrated these two activities throughout the course of their problem solving. This integration was apparent in all of the successful protocols, regardless of the particular solution path followed.

Three different solution paths were followed by successful students in this study: the Local Hypothesis solution path, the Recursive solution path, and the Pursuit solution path. In both the Recursive and the Local Hypothesis paths, students translated observed patterns and relationships into algebraic expressions that eventually produced the final hypothesis. In the Pursuit path, which is instantiated in our cognitive model, students detected patterns and expressed them generally, in terms of x , and then constructed the final hypothesis by combining smaller hypothesis pieces together.

The Pursuit strategy was the most common strategy used for both of the problems in this study. The frequent use of this strategy suggests that the activity of pursuit is often necessary in inductive reasoning. Indeed, inductive problem solving is seldom accomplished in a single flash of insight, especially when the rule to be discovered is complex. In the case of function finding for undergraduates, quadratic polynomial rules were sufficiently complex that students did not solve the problems in a single step. In such situations it becomes necessary to find ways to simplify the problem. In the Pursuit strategy, students simplify problems by identifying and pursuing quantities that are less complex than the original y .

It is important to note here that the solution paths followed by undergraduates are not generally optimal in terms of reaching a solution quickly and efficiently. However, our purpose in this study was not to examine mature, optimal strategies for solving function-finding problems. Instead, we chose function finding as a representative inductive reasoning and mathematics task, and we chose to examine and model the problem-solving activities of nonexperts because we wanted to tap *inductive* processes—not proven, deductive strategies. It is easy enough to solve a polynomial function-finding problem in a noninductive way.¹² If we had examined expert performance on function-finding problems they might well have used formal, noninductive strategies, and we would not

have any inductive processes to study or to model. We purposely examined the activities of bright students in a relatively unfamiliar inductive domain so that we could examine how people *without* domain-specific strategies would approach the problems. It is because we attempted to identify relatively domain-general strategies that these results are applicable to more areas of mathematics than just function-finding problems.

Model Summary

The PURSUIT cognitive model instantiates the Pursuit solution path. As such, it demonstrates that induction of the final hypothesis is not accomplished all at once. Instead, the hypothesis is constructed step by step, out of what we have called puzzle pieces. Each separate algebraic piece is expressed in terms of x and then incorporated into the final solution. The model's highlighting of this process is an important contribution to our understanding of "system construction" inductive reasoning problems (see Klauer, 1996). It would be incredibly difficult to recognize the rule for any complex set of data without first decomposing the problem into simpler components. People do not typically look at the data $\begin{array}{cccccc} X & 3 & 4 & 5 & 6 & 7 \\ Y & 0 & 2 & 5 & 9 & 14 \end{array}$ and simply produce the full hypothesis: $y = x(x - 3)/2$. Not even our fastest successful participant approached such sophistication. Accordingly, the PURSUIT model must engage in three full cycles of relating variables and recognizing patterns before it can compose the pieces required to solve this problem. For more simple functions, however, the story is quite different. People can and do look at the data $\begin{array}{cccccc} X & 3 & 4 & 5 & 6 & 7 \\ Y & 0 & 1 & 2 & 3 & 4 \end{array}$ and very quickly produce the hypothesis that $y = x - 3$ (at least in this participant population). Similarly, our model requires only two productions to solve this single-operator problem. Our model, like our participants, does not solve F1 (the more difficult function) by inspection, but breaks the problem into subproblems and then builds back up to the full hypothesis. Thus, the PURSUIT model emphasizes the importance of reducing a complex problem to a set of simpler problems.

Note that for both the students and the model, the simpler subproblems seem to be inducible almost by inspection. Note also that all of these subproblems require only single-operator relations (e.g., $x - 3$). Indeed, in our model, the "Express-in-terms-of- x " production fires only for single-operator relations. Although this result does not mean that people cannot induce relations that involve more than one operation, it is certainly suggestive.

One final contribution of our model is that it identifies a critical difference between the successful inductive reasoning of our successful participants and the failed attempts of the unsuccessful inducers. Both the successful and the impaired versions of our cognitive model have the necessary procedures to carry out the Pursuit strategy. Both are equipped to recognize patterns and to pursue promising quantities. However, the capacity of each model to recognize patterns is dependent on the repertoire of patterns that we enabled the model to recognize. The successful version is provided with a larger repertoire of number patterns than the impaired version, and is thus capable of succeeding when the impaired model does not. This dependence on pattern recognition enables the PURSUIT model, unlike

prior models of discovery and inductive reasoning (e.g., Qin & Simon, 1990; Huesmann & Cheng, 1973; Gerwin & Newsted, 1977) to account for the fact that the same students who failed at discovering one quadratic function in this study succeeded at solving the other (for which the impaired model did have the necessary pattern in its repertoire). Thus, the model mimics the performance of students who succeed at solving problems that require patterns that they have in their repertoires, and fail at solving problems that require patterns that they do not recognize.

The PURSUIT model instantiates the inductive, nonexpert solution path most commonly exhibited by participants in this study. In doing so, it highlights the importance to inductive reasoning of pattern recognition knowledge as well as the importance of breaking problems down into simpler, “inducible” components that require only one operation to be expressed generally.

Importance of Pattern Recognition

Our model highlights the detection of patterns as crucial to inductive reasoning. Indeed, the pursuit process, which simplifies complex problems, can only occur when pattern detection skills are sufficient to identify quantities that are less complex than the original y . The process of pursuit is thus dependent upon the student’s ability to recognize useful patterns and to thereby make informed, intelligent pursuit decisions. If a student fails to recognize the pattern in a useful quantity, that student may incorrectly conclude that the path represented by that quantity is unproductive, and thus abandon that line of pursuit. Students who lack pattern recognition knowledge are thus more likely to follow unproductive paths, or to abandon paths that would ultimately be productive. In other words, it is not because students do not know to *look* for patterns, but because they do not *find* any patterns that they fail at pursuit. We conclude that the ability to recognize a repertoire of possible patterns (and not just the particular pattern emphasized for the problem in this study) is crucial to inductive reasoning in mathematics.

There is extensive support in the literature for the idea that pattern recognition is important in problem solving. Many studies have shown, for example, that pattern recognition knowledge is a major difference between experts and novices (e.g., Chase & Simon, 1973; Koedinger & Anderson, 1990; Chi et al., 1982). Such pattern recognition necessarily requires domain knowledge, which experts have in abundance. Indeed, in their study of physics problem solving and expertise, Chi et al. (1982) noted that “the problem-solving difficulties of novices can be attributed mainly to inadequacies of their knowledge bases and not to limitations in . . . [their] processing capabilities” (p. 71). Similarly, Simon & Kotovsky (1963) found that, although problem solving procedures are necessary, they are not sufficient for solving serial pattern completion problems; domain knowledge is required as well. Consider the following example. If, in attempting to complete the pattern ABMABN _ _ _, one does not know that N follows M in the alphabet, and that O subsequently follows N , the problem will not be solved, regardless of the inductive skills at hand. One needs to be familiar with the relevant

alphabet to succeed at such problems. In mathematics, and particularly in these inductive reasoning problems, the relevant “alphabet” or “knowledge base” is the number system.

This knowledge base of numbers must encompass knowledge of relationships *between* numbers. For a student to be able to recognize a repertoire of patterns, she must be able to recognize relationships between successive pairs of numerals in a sequence of numbers. The advantage of possessing such knowledge of numerical relations has been noted by Novick and Holyoak (1991), who found that “the best predictors of analogical transfer for [their] problems were mathematical expertise and *knowledge of the numerical correspondences* required for successful procedure adaptation” (p. 412, emphasis added). Pellegrino and Glaser (1982) have also noted the importance of recognizing numerical relationships: “The solution of numerical analogy problems. . . requires a consideration of the knowledge base necessary to represent both the individual numerical stimuli and the relations between pairs of numbers” (p. 302). Other studies of number analogy problems (which, incidentally, are virtually identical to function-finding problems, except that they do not require explicit generalization of the rule in terms of x) have similarly concluded that knowledge of the number system and of numerical relations is critical (Corsale & Gitomer, 1979; Holzman, 1979). Thus, the literature supports the claim that success at inductive reasoning in mathematics necessitates successful pattern finding, and that pattern finding requires facile knowledge of numerical relations.

Educational Implications and Future Work

The results of this study suggest that knowledge of numerical relations may play a more important role in “higher-order” problem solving than is commonly acknowledged. We propose that the ability to detect patterns (and, therefore, the ability to solve problems inductively) is directly related to a participant’s numerical knowledge and speed of access to that knowledge (i.e., recognition rather than computation). This type of knowledge may be related to the concept of “number sense,” which has been characterized as “an intuitive feeling for numbers and their various uses and interpretations” (NCTM, 1991, p. 3). Recently, a number of researchers have targeted number sense as a concept that needs further explication (cf., Case & Moss, 1997; Greeno, 1991; Griffin, Case, & Siegler, 1994), and educators have called for the development of curricula that instruct and/or nurture number sense in students (NCTM, 1989, 1991). We posit that the knowledge of numerical relations identified as useful for our function-finding problems is a component of this number sense. Indeed, knowledge of multiple relationships among numbers is explicitly identified by NCTM in its working definition of number sense (NCTM, 1991). As such, we applaud these efforts to enhance the number sense of students, as we believe enhanced number sense will improve students’ pattern finding skills and thereby improve their higher-order problem-solving abilities.

Our results should also serve as a caution to those who would de-emphasize learning of number facts and numerical relations in favor of focusing instruction on higher-order

thinking and problem-solving skills. The findings from this study suggest that the neglect of number facts might in fact impede progress toward the very goal of improving higher-order thinking and problem solving in mathematics. Of course, the causal relation between numerical knowledge and higher-order problem solving ability remains to be tested directly. This issue is currently being addressed in subsequent work by the first author.

V. CONCLUSION

In summary, we have identified the ability to detect and to symbolically describe data patterns as a crucial aspect of inductive reasoning. Our model and the protocols of participants in our study demonstrate the importance of these activities to solving inductive reasoning problems. We propose that the ability to *detect* patterns is directly related to participants' numerical knowledge base and their speed of access to that knowledge. Hence, we argue that numerical knowledge is a crucial component of inductive reasoning in mathematics.

[The universe] cannot be read until we have learnt the language and become familiar with the characters in which it is written. It is written in mathematical language, . . . without which means it is humanly impossible to comprehend a single word.

Galilei, Galileo
Opere Il Saggiatore, p. 171

Acknowledgments: This work was supported by a National Science Foundation Graduate Fellowship to the first author. Preliminary results from this work were presented at the Annual Meeting of the American Educational Research Association in New York, NY, 1996, and at the Annual Meeting of the Cognitive Science Society in Stanford, CA, 1997.

We wish to thank Herb Simon, Sharon Carver, and John R. Anderson for contributions to the design and theory, Andrew Tomkins for many thoughtful contributions to the exposition of the theory, the data, and the model, Steve Blessing for discussing the design, data analysis, and model at length and for ACT-R tutorials, and Peggy Clark, Anne Fay, Marsha Lovett, Steve Ritter, and Tim Rogers for advice and support along the way. We would also like to thank our reviewers, David Kirshner, Clayton Lewis, and Dan Schwartz, for insightful comments and helpful suggestions.

NOTES

1. Throughout this paper we take care to refer to 'inductive reasoning' or to 'induction in mathematics' and not to 'mathematical induction', which designates an entirely different process. The phrase "mathematical induction" labels a formal method for proving certain kinds of mathematical theorems. Readers may refer to Polya (1945) for an extended explanation of the important difference between this method, which is actually deductive, and inductive reasoning in mathematics.

2. Another way to think of this relation is to consider that all the subsets of a set of n elements can be generated by either including or excluding each of those n elements (i.e., there are two choices at each of n decision points). Thus, multiplying 2 by itself n times yields the number of all possible subsets.
3. This manner of selecting an x -value was designed to prevent participants from generating large instances with great ease. Thus, data could not be generated by typing in the desired "X" value, which would be unrealistic in a real-world setting where one could not generate the data by computer. This restriction places an implicit constraint on the size of the data instances that would be generated by participants, as it is annoying to wait for the clicks to be processed and to listen to their accompanying beeps. We therefore did not expect that any participant would actually generate $f(1000)$. This design feature was meant to encourage students to adopt our goal of producing a closed-form rule to solve the problem.
4. One unsuccessful participant's protocol was lost due to mechanical failure. As a result, several analyses are based only on the remaining 15 participants.
5. Recall that 10 was the maximum number of instances that could be collected. Further instances could be inferred, however, via pattern completion.
6. Most (15 out of 16) participants collected either $x = 1$ or $x = 2$ as well, but here the interface, rather than providing the value of y for these instances, produced the following message. "For this problem, you cannot generate data for less than 3 clicks." The problem was designed in this way to avoid the use of negative numbers in this experiment. Thus, the collection of these instances is interesting only in that we know that participants were attempting to collect them, and we know that the participants were thus provided with the information that their data collection could not include x values less than 3. Some participants did form loose hypotheses about the nature of the sought-after rule based on this information (such as the correct hypothesis that the y -values of the function would be negative below the point where $x = 3$). Note that the request for $x = 1$ or $x = 2$ did not count toward the 10 instances allowed to the participant.
7. One solved the problem very quickly, and thus had an extremely short protocol. This participant's protocol had only one series of codable episodes before reaching the answer, and this entire episode was coded as HG and thus accounts for the apparent disproportionate allocation of effort for this participant. The other participant found the solution to the problem through the use of a recursive formula and Gauss' formula for the summation of n sequential integers. This approach resulted in an unusual amount of PF for this participant.
8. An example route: plug in " $x - 2$ " for " n " to produce $[x - 2] * ([x - 2] + 1) \div 2$. As the formula is for a sequence starting at 1 instead of at 2, we subtract 1 from it: $([x - 2] * ([x - 2] + 1) \div 2) - 1$. Now reduce: $((x - 2) * (x - 1) \div 2) - 1 = ((1/2)x^2 - (3/2)x + 1) - 1 = (1/2)x^2 - (3/2)x = (1/2)(x^2 - 3x) = (1/2)x(x - 3)$. Voila.
9. "Detecting the pattern" means noting in one way or another, and either on paper or verbally, that q increases by a constant for each sequential value of x .
10. Discovering that the quantity $(y - x)/x$ can be expressed in terms of x as $(x - 5)/2$ will lead to the final solution as follows: $(y - x)/x = (x - 5)/2$. $(y - x) = x * (x - 5)/2$. $y = x + x * (x - 5)/2 = x + x * (x/2 - 5/2) = x + (1/2)x^2 - (5/2)x = (1/2)x^2 - (3/2)x = (1/2)x * (x - 3)$.
11. A pilot study suggests some support for this notion. In the study, participants were asked to assess how difficult it would be to have to find the function for each of several sets of x and y data. Participants rated the data for y/x from F1 (0.5, 1, 1.5, 2, . . .) as more difficult to potentially induce than the data for y itself (2, 5, 9, 14, . . .), although in actuality this is not the case. In contrast, for F2, they rated y/x (3, 5, 7, 9, . . .) as simpler than y itself (3, 10, 21, 36, . . .).
12. For example, one could take the differences between the successive y values. If these are constant, then that constant is the coefficient of x , and the function is linear. If these y differences are not constant, but differ by a constant, then that constant is twice the coefficient of the x^2 term and the function is quadratic. Similar algorithms can be used for higher-powered polynomials.

REFERENCES

- Anderson, J. R. (1993). *Rules of the mind*. Hillsdale, NJ: Lawrence Erlbaum Associates.
- Anderson, J. R., Corbett, A. T., Koedinger, K. R., & Pelletier, R. (1995). Cognitive tutors: Lessons learned. *The Journal of the Learning Sciences*, 4, 167–207.
- Bisanz, J., Bisanz, G. L., & Korpan, C. A. (1994). Inductive reasoning. In R. J. Sternberg (Ed.), *Handbook of perception and cognition: Thinking and problem solving* (Vol. 12, pp. 179–213). Orlando, FL: Academic Press, Inc.

- Bjork, R. A. (1968). All-or-none subprocesses in the learning of complex sequences. *Journal of Mathematical Psychology*, 5, 182-195.
- Case, R., & Moss, J. (1997). Developing children's rational number sense: An approach based on cognitive developmental theory. Paper presented at the annual conference on the Psychology of Mathematics Education, Florida, October.
- Chase, W. G., & Simon H. A. (1973). The mind's eye in chess. In W. G. Chase (Ed.), *Visual information processing*. New York: Academic Press.
- Cheng, P. W., & Holyoak, K. J. (1985). Pragmatic reasoning schemas. *Cognitive Psychology*, 17, 391-416.
- Chi, M. T. H., Glaser, R., & Rees, E. (1982). Expertise in problem solving. In R. J. Sternberg (Ed.), *Advances in the psychology of human intelligence*, Vol. 1, pp. 7-75. Hillsdale, NJ: Lawrence Erlbaum Associates.
- Cummins, D. D. (1992). Role of analogical reasoning in the induction of problem categories. *Journal of Experimental Psychology: Learning, Memory and Cognition*, 18(5), 1103-1124.
- Dunham, W. (1990). *Journey through genius*. New York: John Wiley & Sons, Inc.
- Egan, D. E., & Greeno, J. G. (1974). Theory of rule induction: Knowledge acquired in concept learning, serial pattern learning, and problem solving. In L. W. Gregg (Ed.), *Knowledge and cognition*, (pp. 43-103). Hillsdale, NJ: Lawrence Erlbaum Associates.
- Ericsson, K. A. & Simon, H. A. (1993). *Protocol analysis: Verbal reports as data*. Cambridge, MA: MIT Press.
- Evans, T. G. (1968). Program for the solution of a class of geometric-analogy intelligence-test questions. In M. Minsky (Ed.), *Semantic information processing*. Cambridge, MA: MIT Press.
- Gerwin, D. & Newsted, P. (1977). A comparison of some inductive inference models. *Behavioral Science*, 22, 1-11.
- Goldman, S. R., & Pellegrino, J. W. (1984). Deductions about induction: Analyses of development and individual differences. In R. J. Sternberg (Ed.), *Advances in the psychology of human intelligence* (Vol. 2, pp. 149-197). Hillsdale, NJ: Lawrence Erlbaum Associates.
- Greeno, J. G. (1991). Number sense as situated knowing in a conceptual domain. *Journal of Research in Mathematics Education*, 22, 170-218.
- Gregg, L. W. (1967). Internal representations of sequential concepts. In B. Kleinmuntz (Ed.), *Concepts and the structure of memory*. New York: Wiley.
- Griffin, S., Case, R., & Siegler, R. S. (1994). Rightstart: Providing the central conceptual prerequisites for first formal learning of arithmetic to students at risk for school failure. In K. McGilly (Ed.), *Classroom lessons*. Cambridge, MA: MIT Press.
- Huesmann, L. R. & Cheng, C. (1973). A theory for the induction of mathematical functions. *Psychological Review*, 80(2), 126-138.
- Hunt, E. (1974). Quote the Raven? Nevermore! In L. W. Gregg (Ed.), *Knowledge and cognition*. Potomac, MD: Lawrence Erlbaum Associates.
- Johnson-Laird, P. N. (1983). *Mental models*. Cambridge, MA: Harvard University Press.
- Klahr, D., & Wallace, J. G. (1970). The development of serial completion strategies: An information processing analysis. *British Journal of Psychology*, 61, 243-257.
- Klauer, K. J. (1996). Teaching inductive reasoning: Some theory and 3 experimental studies. *Learning and Instruction*, 6(1), 37-57.
- Koedinger, K. R., & Anderson, J. R. (1989). Perceptual chunks in geometry problem solving: A challenge to theories of skill acquisition. In *Proceedings of the Eleventh Annual Conference of the Cognitive Science Society*. Hillsdale, NJ: Lawrence Erlbaum Associates.
- Koedinger, K. R., & Anderson, J. R. (1990). Abstract planning and perceptual chunks: Elements of expertise in geometry. *Cognitive Science*, 14, 511-550.
- Koedinger, K. R., & Anderson, J. R. (1998). Illustrating principled design: The early evolution of a cognitive tutor for algebra symbolization. *Interactive Learning Environments*, 5, 161-180.
- Kotovsky, K., & Simon, H.A. (1973). Empirical tests of a theory of human acquisition of concepts for sequential patterns. *Cognitive Psychology*, 4, 399-424.
- Langley, P., Simon, H., Bradshaw, G., & Zytkow, J. (1987). *Scientific discovery*. Cambridge, MA: MIT Press.
- National Council of Teachers of Mathematics. (1989). *Curriculum and evaluation standards for school mathematics*. Reston, VA: NCTM.
- National Council of Teachers of Mathematics. (1991). *Developing number sense in the middle grades*. Reston, VA: NCTM.
- Newell, A., & Simon, H. A. (1972). *Human problem solving*. Englewood Cliffs, NJ: Prentice-Hall.

- Novick, L. R. & Holyoak, K. J. (1991). Mathematical problem solving by analogy. *Journal of Experimental Psychology: Learning, Memory, and Cognition*, 17(3), 398–415.
- Pellegrino, J. W., & Glaser, R. (1982). Analyzing aptitudes for learning: Inductive reasoning. In R. Glaser (Ed.), *Advances in instructional psychology* (Vol. 2). Hillsdale, NJ: Lawrence Erlbaum Associates.
- Polya, G. (1945/1973). *How to solve it* (2nd ed.). New York: Doubleday.
- Polya, G. (1954). *Induction and analogy in mathematics: Volume I of Mathematics and plausible reasoning*. Princeton, NJ: Princeton University Press.
- Qin, Y. & Simon, H. A. (1990). Laboratory replication of scientific discovery processes. *Cognitive Science*, 14, 281–312.
- Raven, J. C. (1938). *Progressive matrices: A perceptual test of intelligence*. London: Lewis.
- Schoenfeld, A. H. (1985). *Mathematical problem solving*. Orlando, FL: Academic Press.
- Serra, M. (1989). *Discovering geometry: An inductive approach*. Berkeley, CA: Key Curriculum Press.
- Simon, H. A., & Kotovsky, K. (1963). Human acquisition of concepts for sequential patterns. *Psychological Review*, 70, 534–546.
- Simon, H. A., & Lea, G. (1974). Problem solving and rule induction: A unified view. In L. W. Gregg (Ed.), *Knowledge and cognition* (pp. 105–127). Hillsdale, NJ: Lawrence Erlbaum Associates.
- Simon, H. A., & Sumner, R. K. (1968). Pattern in music. In B. Kleinmuntz (Ed.), *Formal representation of human judgment*. New York: Wiley.
- Singley, M. K., & Anderson, J. R. (1989). *Transfer of cognitive skill*. Hillsdale, NJ: Erlbaum.
- Sternberg, R. J., & Gardner, M. (1983). Unities in inductive reasoning. *Journal of Experimental Psychology: General*, 112, 80–116.
- Sternberg, R. (1977). Component processes in analogical reasoning. *Psychological Review*, 84, 353–378.
- Zhu, X., & Simon, H. A. (1987). Learning mathematics from examples and by doing. *Cognition & Instruction*, 4(3), 137–166.

APPENDIX A: Coding

TABLE 1

Coding of the 6,331 segments of verbal protocol provided for F1 from 15 participants resulted in a fine-level coding scheme that consists of 176 fine-level codes. These fine-level codes describe every mathematical process observed in the protocols. These codes are grouped into 16 broad codes. These 16 codes are listed below. They are grouped according to three general areas of activity: Data Gathering, Pattern Finding, and Hypothesis Generation.

APPENDIX A, Table 1
Broad-level Coding Scheme

16 Broad-level Codes	Mathematical examples and Excerpts from the Protocols (in italics)
<i>Data Gathering</i>	
1. Reorganize Data	
2. Focus on Subset of Instances	"let's just concentrate on the single digit numbers; let's just concentrate on 4 through 6; that would make my life much easier; and then we can work from there." (P1, 1393–397)
3. Focus on Y-values	
4. Examine variables other than X & Y	
<i>Pattern finding</i>	
5. Detect Feature of the Data	"the only one that isn't a; the result isn't divisible by the initial number minus 3; is the 7" (P7, 289–292)
6–8. Produce quantities:	
6. Compute relations within X or Y	Compute differences between successive y values
7. Compute relations between X & Y	Compute $y - x$, or $y \div x$
8. Compute relations involving transformed X's or Y's	Compute difference between " $x - 3$ " and " y ".
9. Detect Pattern in the Data	"um. let's see from; by increasing by 1; it increases by; ok; so as X increases by 1; Y increases by; 2, 3, 4" (P2, 50–56)
10. Test an Expressed Pattern	"7 times 2 is 14, 9 times 3 is 27, 5 times 1 is 5. so that means 11 times 2; it's Y is going to be; or 11 times 4. this Y is going to be 44; yeah that's right; for 11; it's going to be 44." (P3, 172–181)
<i>Hypothesis Generation</i>	
11. Build Hypothesis, piece-by-piece	"Y equals something minus 3; but there's something more than that, that's not all. Y equals X minus 3, but there's something happens to the X; and; that something minus 3, . . . so 5; subtract off; 3; gives us 2; now how do we make 2 equal 5; 2 X plus 1?" (P11, 72–910)
12. Choose hypothesis form/Use standard technique to construct hypothesis	"this looks like a series; . . . ok, let's go back to find this formula for X. so; it's the integral as it goes from 1 to; as X goes from; 3; to 1000; of; you just keep adding them." (P6, 307–329) (P6 attempted to construct a hypothesis using the technique of integration.)
13. Propose Hypothesis	"I'm going to see if it could be X squared." (P3, 92)

**APPENDIX A, Table 1
Continued**

16 Broad-level Codes	Mathematical examples and Excerpts from the Protocols (in italics)
14. Test Hypothesis	
15. Discard	
16. Impasse	<i>“factoring that gives me; 17 times 5 times 2 I don’t know I don’t see any patterns there either” (P15, 88–101)</i>

TABLE 2

To briefly illustrate the detailed nature of the fine-level coding scheme, we have used a few of the broad codes listed above (numbers 1, 7, and 11) as examples. For each of these we have listed the complete set of fine-level codes that belong in that broad code category.

**APPENDIX A, Table 2
Samples from Fine-level Coding Scheme**

Broad Code	Fine-level Codes Included in that Broad Code
1. Reorganize Data	Re-record data Reorganize table Redraw table
7. Compute relations between X & Y	Compute $x \pm y$ differences Compute second-order $x - y$ differences Factor the $x - y$ differences Factor pairs of y with x as factor Compute $x^* c = y$ Compute $x/c = y$ Compute ratio x/y or y/x Compute percentage of x/y or y/x
11. Build Hypothesis, piece-by-piece	Analyze discrepancies Isolate specific data feature for explanation Build local level functions, across instances Propose function/hypothesis based on single instance Test local hypothesis on other instances

APPENDIX B:
Successful Participant (Ace)

-
- | | |
|--|--|
| <p>1 so I push "click here"
 2 and this is my X task here?
 3 how many times I click here is my X thing?
 4 [E: yes]
 5 so if I click it 10 times
 6 that'd give me a good number to start with.
 7 [Interface: $X = 10, Y = 35$]
 8 [E instructs participant to use new sheet of
 9 paper to write on rather than the instructions]
 10 when X equals 10 Y equals 35
 11 so I now think the formula was Y,
 12 Y equals X times 3.5.
 13 I'll make X 2
 14 now does this start a new X?
 15 [E: yes]
 16 [Interface: $X = 2$, fail]
 17 ok.
 18 [E: prompt to speak]
 19 I just feel confused.
 20 ok
 21 so I was thinking Y equals X times 3.5
 22 so now I'm going to use 3 and see what that
 23 does
 24 [Interface: $X = 3, y = 0$]
 25 zero, huh?
 26 I don't like that.
 27 so that one was wrong
 28 X equal 10, Y equals 35
 29 X equals 3, Y equals 5.
 30 I really don't want to push this button a
 31 hundred times, do I?
 32 maybe I will.
 33 maybe I'll push it 50 times.
 34 [Interface: $X = 50, Y = 1175$]
 35 [E: prompt to speak]
 36 I have no idea.
 37 I have no idea.
 38 really confusing me.
 39 ok.
 40 I'm not really thinking a whole lot.
 41 X equals 10, Y equals 35.
 42 I'm trying to decide what Y equals when
 43 X equals 1000, huh?
 44 [E: right]
 45 hm.
 46 so obviously it's not multiplication
 47 try 5.
 48 [Interface: $X = 5, Y = 5$]
 49 [long pause, E: "so what just happened?"]
 50 I just typed in 5 for X and got 5 for Y.
 51 [E explaining to talk through everything.]
 52 so I'm supposed to say I'm thinking
 53 "1, 2, 3, 4, 5"?</p> | <p>54 [E: yes, everything.]
 55 just think out loud.
 56 so I'm thinking how to relate these two
 57 numbers.
 58 I'm still lost.
 59 [E: it's ok.]
 60 I'm think I'm preoccupied with talking
 61 instead of thinking.
 62 [E: you'll get the hang of it.]
 63 hm.
 64 I can see no relationship at this point.
 65 I think this thing's generating random
 66 numbers,
 67 so I'm going to push X equals 5 again.
 68 [E: It doesn't do that.]
 69 ok.
 70 so I won't do that.
 71 so I'm thinking of a new number to try,
 72 and I don't really know a good one.
 73 I'll try 25.
 74 I'm using
 75 because I want to compare 5 and 10 and 25
 76 and 50.
 77 [Interface: $X = 25, Y = 275$]
 78 7 times
 79 275 times
 80 nope.
 81 3 times X,
 82 Y equals zero.
 83 well I was thinking it could X times 2 minus
 84 X times 1.5.
 85 that wasn't right either.
 86 I'm going to see if it could be X squared.
 87 I'm gonna try 4,
 88 just cuz I tried 3 and 5.
 89 [Interface: $X = 4, Y = 2$]
 90 I got 2.
 91 so as X increases by 1,
 92 Y increases
 93 I'm gonna try 6,
 94 just to see the pattern.
 95 [Interface: $X = 6, Y = 9$]
 96 I get 9.
 97 so I'm thinking.
 98 X divided by
 99 some kind of fraction involved.
 100 ok.
 101 1 over X,
 102 1.
 103 could be a square root involved
 104 that'd be pretty hard.
 105 oh, I'll try 7.
 106 [Interface: $X = 7, Y = 14$]</p> |
|--|--|
-

APPENDIX B:
Continued

-
- | | |
|--|---|
| <p>107 14.
108 ok, so I'm looking for
109 0 to 2, is jump of 2,
110 2 to 5, jump of 3,
111 5 to 9, jump of 4,
112 9 to 14 is a jump of 5.
113 4, 5
114 so
115 X.
116 X minus 2
117 is the increment of that jump.
118 from the number before.
119 doesn't work for the first number.
120 so
121 X minus 2 is the increment
122 would be
123 6
124 8
125 make it 20
126 so there's 9
127 make it 27
128 there's 10
129 you make 35.
130 figure that out.
131 how apply it to 1000
132 so X minus 2 is the increment of that jump
133 and when X equals 3, Y equals 0.
134 so
135 when X equals 1000.
136 it increments
137 gonna be 998
138 times that number.
139 how do I figure out that number
140 so it's Y minus 1?
141 it starts at zero,
142 go up by increments of
143 but what is the rule
144 plus X minus 2
145 Y equals
146 the previous Y
147 plus X minus 2
148 how do you find the previous Y?
149 no good formula
150 previous Y
151 look at the 2 rows of numbers to see if I can
152 devise a way to get Y.
153 now I'm thinking it has to do with
154 something with X used to a power.
155 I can't figure out a way to get Y.
156 let's see,
157 when X equals 3,
158 Y is equal
159 when X is 4, Y is 2.
160 cuz it goes up X minus 2.
161 but there should be a way to get Y</p> | <p>162 without doing that.
163 7 times 2 is 14.
164 9 times 3 is 27
165 5 times 1 is 5.
166 so that means 11 times 2
167 it's Y is going to be
168 or 11 times 4,
169 this Y is going to be 44.
170 yeah, that's right.
171 for 11,
172 it's going to be 44.
173 so
174 Y times 1,
175 Y times 2,
176 Y equals X times
177 Y equals X times 3,
178 so
179 8 times 2.5,
180 what's that equal?
181 4 times
182 not working.
183 that's not right either.
184 16, 20,
185 yeah that's it.
186 so Y equals Y times 2.5.
187 [E: prompt to speak up]
188 yeah.
189 I've figured out how to get Y now,
190 but I don't know how to make a generic
191 formula.
192 figured out 2 ways to get Y.
193 Y equals previous Y plus X minus 2.
194 or
195 Y equals X
196 times .5 of
197 no, plus .5
198 time goes up by .5.
199 how do you do that generically?
200 yeah, because 4 times .5 is 2.
201 so
202 Y equals X times .5 for 4
203 Y equals X times 1 for 5
204 and goes up by .5 each time.
205 so that would be
206 how do you do this
207 1.5
208 so would be
209 use that 3 number.
210 so
211 after 3 it goes up by .5 each time.
212 is at 3
213 and a half
214 4 was at .5
215 5 was at 1
216 6 was at 1.5</p> |
|--|---|
-

APPENDIX B:
Continued

217 trying to see	271 so
218 how you move the .5 up every time,	272 if I have
219 generically.	273 15
220 so 6 divided by 3	274 I'll try 15.
221 is 2.	275 15.
222 is that right?	276 so my answer should be
223 5 divided by 3,	277 15 minus 3
224 4 divided by 3,	278 12
225 no don't want to do that.	279 divided by 2
226 still trying to think of a way to move this up	280 6
227 going through all the ones I've already	281 15 times 6
228 thought of	282 and 90.
229 and I can't figure out a way to make it go up	283 so I'm going to try 15 now.
230 with the X.	284 and the answer is
231 Y equals	285 [Interface: $X = 15, Y = 90$]
232 X times	286 90.
233 how do I get that .5	287 yeah I think that's it.
234 would be	288 [E: confidence?]
235 4 minus 3	289 I'd have to say 7 now.
236 if I have X	290 It's probably wrong.
237 we try	291 [E: It's right.]
238 5 minus 3 divided by 2	292
239 get us the 1	293 [E: How did you do that?]
240 so that would be	294 I could only think clearly when I wasn't
241 $X - 3$ divided by 2	295 talking.
242 try 4 minus 3 divided by 2	296 Cuz I was trying to do two different things
243 that's 1.5	at
244 .5	297 once.
245 try 8 minus 3 divided by 2	298 [E: I gotta figure out how you did it though,
246 that equals the 2.5 that we need.	299 so how'd you do it?]
247 so we have	300 um,
248 Y equals X times	301 well first of all,
249 X minus 3	302 I looked in here
250 divided by 2.	303 [E: differences between Y's]
251 right?	304 yeah and I was looking at increment,
252 Y equals 10 times	305 but then I couldn't
253 10 minus 3 divided by 2.	306 decide on the way, you know, to do that.
254 so minus 3 is 7	307 so then
255 7 divided by 2	308 for some reason
256 is	309 I don't know why exactly
257 3.5	310 but I started looking
258 10 times 3.5	311 I saw how this was 5 times 1 equals 5,
259 35.	312 and then this was X times 2 equals Y,
260 think I figured it out.	313 this was X times 3 equals Y,
261 [E: ok what do you think it is?]	314 [E: so you factored the Y's whenever the X
262 Y equals X times X minus 3 over 2.	315 looked like it was one of the factors?]
263 [E: confidence on a scale of 1 to 7?]	316 yeah
264 about 6, 7,	317 and that's when I
265 [E: 6 or 7?]	318 I looked at 11 and 44
266 yeah.	319 after I started looking at these,
267 oh wait,	320 and that came out to be 4, too.
268 I got 2 more tries on this thing.	321 and then after that I got stuck again.
269 let me try real quick.	322 [E: 11 and 44, what?]
270 [E: ok.]	323 it came out to be 11 times 4.

**APPENDIX B:
Continued**

<p>324 like, it was 9 times 3, 325 it was 11 times 4. 326 [E: oh, so every other one went up by 1, 327 that's what you noticed.] 328 yeah, and I didn't catch that at first 329 cuz I was trying to 330 [E: and they were going up by .5. ok.] 331 I didn't catch that at first cuz I was trying to 332 talk into here. 333 [E: ok.] 334 I was thinking. 335 and that's when I shut up for a while. 336 and then I realized 337 well, X times .5 was 2. 338 so then I went through and got that, 339 that part of it. 340 [E: so what did you have at that point? you 341 had that Y equals] 342 X times .5. 343 I just knew that 344 [E: X times that number increasing by .5] 345 and I, yeah, 346 [E: and then you had to figure out how] 347 I had to figure out how to get that number. 348 [E: so how'd you do that?] 349 good question. 350 um, 351 um, yeah. 352 [E: seemed to me like just all of a sudden 353 you had it.] 354 yeah, that's kind of what it is,</p>	<p>355 it just kind of kicked out of nowhere. 356 cuz I looked at it for like, maybe 5 minutes. 357 I couldn't figure out how to get that number 358 and then for some reason I just took 359 [E: you realized that it was] 360 yeah, I took this one. 361 [E: that for 5, it was 5 minus 3 over 2, and 362 so then you tried the minus 3 over 2 for all 363 of them?] 364 well, see, yeah, the reason I picked 5 365 because it was the one where they were 366 equal 367 [E: equal, right.] 368 and I knew 369 [E: had to get back to 5] 370 yeah. 371 [E: you had to figure out how to get from 5 372 to 1, and you did that by doing 5 minus 3 373 over 2] 374 yeah, that's exactly how I did it. 375 I had to figure out how to get from 5 to 1. 376 [E: and at that point did you just try the 377 same formula] 378 yeah, I went down here 379 [E: with 4 and then you tried it with 8? and 380 then you figured it was right?] 381 yeah. 382 well, yeah. 383 and then I did this one because I remember I 384 had 2 tries left, yeah. 385 [E: very good.]</p>
---	---

**APPENDIX D:
Productions of the PURSUIT Model**

Relate-by-addition	PF
IF	have a source-derived quantity, S, and a pursuit quantity, P, AND have not yet computed ($S + ? = P$),
THEN	compute P-S. Identify this quantity as being pursuit-derived.
Relate-by-subtraction	PF
IF	have a source-derived quantity, S, and a pursuit quantity, P, AND have not yet computed (S-P),
THEN	compute S-P. Identify this quantity as being pursuit-derived.
Relate-by-multiplication	PF
IF	the goal is to find a relationship between the source quantity, S, and the pursuit quantity, P,
THEN	for each instance of S and P find the value you need to multiply S by to get P and create a new quantity that contains these values. Identify this quantity as being derived from P.
Find-differences-within-quantity	PF
IF	have a pursuit quantity, P, and have not yet computed P differences,
THEN	compute P differences. Identify this quantity as being pursuit-derived.
Examine-numerator	PF
IF	have a pursuit quantity, P, with fraction values and a common denominator of d,
THEN	create a new quantity, $d*P$, to examine the numerator of the quantity P. Identify this quantity as being pursuit-derived.
Recognize-pattern	PF
IF	have a pursuit-derived quantity, P, that fits one of the patterns in the repertoire,
THEN	designate P a pursuit quantity.
	Patterns: constant counting-numbers odd-numbers even-numbers differs-by-halves
Express-in-terms-of-X (additive)	PF, HG
IF	x and a pursuit quantity, P, differ by a constant, c,
THEN	record $x - c$ as the formula that yields P.
Express-in-terms-of-X (multiplicative)	PF, HG
IF	x and a pursuit quantity, P, differ by a constant multiple, c,
THEN	record $x \div c$ as the formula that yields P.
Unwind-subtraction	HG
IF	a hypothesis $f(x)$ yields a pursuit quantity, P1, and P1 is the discrepancy between some other pursuit quantity P2 and x, so that $P1 = P2 - x$,
THEN	propose a new hypothesis that $f(x) + x$ equals P2.
Unwind-multiplication	HG
IF	a hypothesis $f(x)$ yields a pursuit quantity, P1, and P1 equals $c*P2$, where P2 is another pursuit quantity,
THEN	propose the new hypothesis that $f(x)/c$ equals P2.
Unwind-division	HG
IF	a hypothesis $f(x)$ yields a pursuit quantity, P1, and P1 equals $P2/x$, where P2 is an earlier pursuit quantity,
THEN	propose the new hypothesis that $x*f(x) = P2$.
Test-hypothesis	HG
IF	have a hypothesis that yields y and has not yet been tested successfully,
THEN	check that hypothesis against some instance and record the result as successful or not.
Finish	HG
IF	have a hypothesis that yields y and has been tested successfully,
THEN	pronounce the problem solved.
